



ROTARY MULTI-DISC MOWERS

FPM 627 712
FPM 627 713
FPM 627 726
FPM 627 678



ASSEMBLY / OPERATION / MAINTENANCE SPARE PARTS LIST

03.2017

• Email: razvoj @ fpm-agromehanika.rs
info @ fpm-agromehanika.rs
prodaja @ fpm-agromehanika.rs

SERBI

• Web: www.fpm-agromehanika.rs

USER WARNING

By buying this machine, you have made a wise choice. Many years of thought, research, and perfectionism have been invested in it. Like thousands of other users, you will also realise that you currently own a machine created by state-of-the-art engineering, know-how and field testing. You have purchased a reliable machine, however good performance and long service life may be expected only if you use it properly.

This user manual contains all of the necessary information for achieving optimal performance with your machine. However, this performance depends on how thoroughly you have read this manual and applied the knowledge. This is a simple machine; however, many obvious defects resulting from poor performance may be overlooked due to neglecting natural wear and tear of wearing parts, or operating a poorly adjusted machine. Do not think you know how to operate and maintain the machine before reading this manual you should always have at hand.

Our service representatives and sales and service centres with trained personnel offer you original parts for your rotary mower. These parts are manufactured and carefully inspected at the same facility where mowers are produced, in order to ensure high quality and precision assembly upon replacement.

ROTARY MULTI-DISC MOWERS MANUFACTURED BY: FPM AGROMEHANIKA D00 BOLJEVAC.

Rotary multi-disc mowers meet the requirements of the Machine Safety Regulation (Official Gazette of the Republic of Serbia No. 13/2010) with regard to stability and protection of parts or assemblies that may put the operator at risk with its function or form.

IMPROVEMENT: FPM Agromehanika d.o.o. strives to continuously improve its products and therefore reserves the right of modification or improvement, without having to modify or improve previously manufactured or sold equipment.

The specifications given in this manual are correct as of date of issue.

All print and image rights are reserved by:
FPM AGROMEHANIKA DOO BOLJEVAC

**DECLARATION OF CONFORMITY WITH THE SAFETY REGULATIONS SET OUT IN THE
DIRECTIVE 2006/42/EC IS AN INTEGRAL PART OF THIS OPERATION AND MAINTENANCE
MANUAL.**



Issued by: FPM AGROMEHANIKA Boljevac
Printed:
Year: 03.2017.

PLEASE READ CAREFULLY!

You will find warning labels “ATTENTION;” “CAUTION;” and “DANGER” in this manual and on the machine. The warnings bring your attention to personal safety and safety of others who work with you, since they need to read the warnings, too.

PERSONAL SAFETY

ATTENTION: The word “ATTENTION” is used where the operator’s and other individuals’ safety from accidents is required.

CAUTION: The word “CAUTION” is used to indicate a potential risk for the operator and other personnel of serious injury that may occur suddenly. This word is used frequently as a warning for the operator and other individuals for the purpose of preventing a surprise when using the mower.

DANGER: The word “DANGER” is used to indicate forbidden action that may involve risk.

ALL ADDITIONAL WARNINGS SUCH AS “NOTICE” AND “IMPORTANT” INDICATE SPECIAL SAFETY-RELATED INSTRUCTIONS REGARDING THE MOWER.

MOWER SAFETY

NOTICE: THIS SINGLE WORD WARNS THE OPERATOR ABOUT POTENTIAL RISK OF MOWER DAMAGE IN CASE OF FAILURE TO OBSERVE PARTICULAR INSTRUCTIONS.

IMPORTANT: THE READER IS INFORMED ABOUT THINGS TO KNOW FOR THE PURPOSE OF PREVENTING MINOR DEFECTS IN CASE HE/SHE MISSED THEM.

WARNING!

IN CASE OF FAILURE TO OBSERVE ANY OF THE ABOVE WARNING LABELS, “CAUTION,” “ATTENTION,” AND “DANGER”, SERIOUS PHYSICAL INJURY MAY OCCUR.

LIMITED WARRANTY

For each original unit delivered to the user by the FPM Agromehanika AD Boljevac distribution network, the manufacturer issues a warranty in accordance with the Standardization Act and Machinery Safety Regulation (Official Gazette of the Republic of Serbia No. 13/2010) guaranteeing that each mower part is new, free from defects in materials and workmanship, for the period of one year from the date of delivery of the machinery to the end user, subject to condition that the machinery is used and maintained in accordance with the instructions given in this operation and maintenance MANUAL.

EXCEPTIONS:

- 1.- Wooden parts are not covered by the warranty.
- 2.- Parts not manufactured by FPM Agromehanika AD Boljevac (rubber and plastic components, belts connecting PTO shaft, PTO shaft guard, hydraulic cylinder with connection tubes etc.) are not covered by this warranty, but by the respective manufacturer's warranty.
- 3.- Parts subject to normal wear and tear during use, such as: V-belts, cutters, tires, swath boards, cutter brackets, sliders under the cutting unit, canvas cover.
- 4.- The warranty lapses in case of misuse or abuse, improper or negligent use, or accident damages. The warranty also expires in case of using non-original parts, and the manufacturer may not be held liable for any transport damages.

THE MANUFACTURER MAY NOT BE HELD LIABLE FOR ANY LOST PROFITS AS A RESULT OF MOWER DEFECT OR INJURIES TO THIRD PARTIES, NEITHER FOR ADDITIONAL COSTS INCURRED FOR REMOVING AND REPLACING PARTS.

The buyer shall be liable and bear the costs for:

- 1.- Regular maintenance, such as lubrication, refilling oil, small adjustments, etc.
- 2.- Transport of the machinery to the service location and back within the warranty period.
- 3.- Travel time of the authorized service representative to the mower owner and back, or delivery of the mower to and from the workshop after the repair.

This warranty does not apply to a mower that has been altered or modified without our express permission, or repaired by another person outside the authorized service.

The warranty is subject to strict observance of the warnings:

- any warnings given in this manual must be observed, and all protective covers regularly inspected and replaced, as required.



















A warranty for parts that are not new is excluded.

Individuals working in our production plant are not its official representatives and are therefore not authorized to assume any obligations in its name or on its behalf.

No warranty shall cover product equipment in excess of that specified, and the manufacturer may not be held liable for injuries resulting from such use.

SAFETY

Most accidents occur during work, maintenance, or transport due to non-observance of the fundamental safety requirements. This is why you are the most important person for operating and maintaining your mower. Regardless of whether you are working alone, with your family members, or with other persons, always read and observe the basic method of operation. Additionally, warning labels are affixed to the mower that serves as a reminder to always observe safety practices.

-  - The indicated operation, maintenance and safety instructions must be strictly observed at all times in order to ensure safe and secure mower operation.
-  - Before beginning work, the operator must be aware of the functioning principle of all of the mower components. It may be too late for that during work. First and foremost, learn how to disconnect the mower quickly and safely in case of emergency.
-  - The operation and maintenance manual must be kept for the entire service life of the machine.
-  - Metal nameplate must always be legible, visible and clean.
-  - When attaching or detaching the mower to or from the tractor, always put the support foot in the appropriate position (safety).
-  - Be especially careful when attaching or detaching the mower to or from the tractor; the area around the lifting device is dangerous.
-  - Check the tractor front wheels for damages prior to operation. Attach weights to the provided place.
-  - Observe the maximum permissible axle load and total weight. Due to the added weight, the load is redistributed on the wheel axles.
-  - Use a cab tractor for road safety requirements. Keep all windows closed during operation.
-  - Prior to starting the mower, even for a very short distance, always bring it in its transport position. Observe the permissible overall dimensions for transport.
-  - Prior to driving on public roads, secure the mower for safe transport and observe the road traffic regulations.
-  In special circumstances, use lights to signal danger, if not contrary to traffic regulations.
-  - Never transport others on the mower or the tractor during work or transport.
-  - Never transport an unsecured mower.
-  - Never transport an operating mower.
-  - Never turn on the connection shaft when the mower is in the transport position.
-  - Never leave the driver's seat when the tractor operates.
-  - Every time before using the mower check whether all parts (nuts, screws, etc.) are sufficiently tightened, and secure the discs and cutters.
-  - If worn out or damaged, cutters, discs and their fasteners (nuts, screws, etc.) must be replaced with FPM AGROMEHANIKA d.o.o BOLJEVAC original parts.

- ⚠ - For safety reasons, check whether the canvas cover is properly secured and attached to the frame. If damaged or worn out, replace it immediately with original cover by FPM AGROMEHANIKA DOO BOLJEVAC.
- ⚠ - Before adjusting, lubricating, or cleaning the mower, lower it to the ground, turn off the tractor engine, remove the ignition key, turn off the PTO shaft, and apply the tractor parking brake.
- ⚠ - Wait until all moving parts have come to a stop before approaching the mower.
- ⚠ - Keep away from all mower parts while working.
- ⚠ - Never wear baggy clothes that may be caught into the rotating mower components. Always wear tight-fitting clothes. Always wear personal protective equipment, safety goggles, protective gloves and footwear, especially when working on rocky soil.
- ⚠ - Fasten the PTO shaft guard with the provided chains. (PTO shaft guard may not turn). If the guard is damaged, replace it immediately.
- ⚠ - The operator must ensure that no individuals or animals are in the work area of the mower, prior to switching the mower on and beginning work. Always keep the consequences of irresponsible and unsafe work in mind, since this may cause grave harm.
- ⚠ - Remove all foreign objects from the field prior to beginning work.
- ⚠ - Never work near the roads, pedestrian areas, public spaces (parks, schools, etc.), and or rocky soil, in order to avoid risk of accidents resulting from ejected objects.
- IMPORTANT:**
- ⚠ - Never work when driving in reverse.
- ⚠ - Unauthorised persons, persons without a driving licence, or persons without appropriate mental and physical abilities are strictly forbidden to operate the mower.
- ⚠ - Only reliable individuals are permitted to operate the mower. Children under 16 are strictly forbidden to operate the mower.
- ⚠ - Only work under optimal light and visibility conditions.
- ⚠ - After the end of the season, authorized service technician should inspect your mower, bring it to operable condition, especially regarding the rotor cutters, and tighten all parts (nuts, screws, etc.) with a required tightening torque.









NEVER IGNORE THESE WARNINGS.



SAFETY

ATTACHING THE MOWER TO THE TRACTOR









-  - Before coupling and decoupling the mower to or from the tractor, lock the hydraulic controls in order to prevent unintended raising or lowering.
-  - When coupling your tedder, observe the category of the tractor and tedder linkages; they have to match.
-  - The area around the attachment points is especially hazardous. There is a risk of injury when coupling linkages.
-  - Never stand between the tractor and the mower when using external hydraulic controls.
-  - Watch out for and prevent any lateral movement of the linkages when the mower is in the transport position.
-  - When driving on public roads with the mower in the transport position, tractor hydraulic controls must be locked in order to prevent unintentional lowering.
-  - Never use the mower on sloped terrain, or transport the mower by using a tractor with a narrow wheel track.







NEVER IGNORE THESE WARNINGS.

SAFETY

USING THE PTO SHAFT

-  - Only PTO shafts supplied with the tedder and approved by the manufacturer may be used.
-  - All PTO shaft guards must be attached and in orderly condition.
-  - Ensure proper pipe overlap in the transport and operating position.
-  - Attaching and removing the PTO shaft may be performed only when the tractor output shaft and the engine are turned off, and the ignition keys are removed.
-  - Place the star ratchet clutch towards the tedder when attaching the PTO shaft.
-  - Always make sure to properly attach the PTO shaft.
-  - Secure the PTO shaft guards with the chains from rotating; always observe the instructions for the PTO shaft.
-  - When the mower is not in operation, always secure the PTO shaft with a chain as shown in Figure 54 (page 34).

-  - If you have doubts about the PTO shaft operation, or if the shaft guard is missing, worn or broken, replace the PTO shaft labelled with a CE mark.
-  - Before turning on the tractor output shaft, check whether the selected number and direction of rotation match with the permissible number and direction of rotation of the mower.
-  - Before turning on the tractor output shaft, ensure that persons and animals are removed from the danger area.
-  - Never switch the output shaft on when the tractor engine is turned off.
-  - If the PTO shaft is damaged, eliminate the defect immediately; It is recommended to contact the service centre before using it again. Improper repairs may lead to PTO shaft imbalance, which may cause poor operation or damages to the mower or the tractor output shaft.











NEVER IGNORE THESE WARNINGS.



S A F E T Y

MOWER HYDRAULIC INSTALLATION

-  - The mower hydraulic installation is under high pressure (maximum operating pressure is 200 bar).
-  - When attaching the hydraulic cylinder, pay special attention to the required connections on the cylinder side and the hydraulic line side.
-  - When attaching the hydraulic lines to the tractor hydraulic, always depressurise the hydraulic installation both on the tractor and mower side.
-  - It is recommended to mark the functional connections between the tractor and the machinery in order to avoid faulty connection. Faulty connection of the opposed functions (lowering and raising) may cause accidents.
-  - Inspect the hydraulic lines (pipes) regularly and replace them after five years. Replace damaged or prematurely worn lines immediately. The replaced lines must comply with the manufacturer's requirements.
-  - When inspecting the lines where there is condensation, always use the appropriate PPE, in order to avoid risk of injury.
-  - High pressure fluid ejection may penetrate the skin and cause an injury. If injury occurs, seek medical attention immediately! Risk of infection!
-  - Before working on the hydraulic installation, lower the mower to the ground, depressurise the hydraulic installation and turn off the tractor engine.



NEVER IGNORE THESE WARNINGS.

WARNING LABEL

FPM Boljevac

The following warning labels are affixed to your mower for your safety and the safety of others working with you. Holding the manual in your hand, walk around the machine and check all warning labels and instructions from the manual. The labels must be legible. If not, they must be replaced.

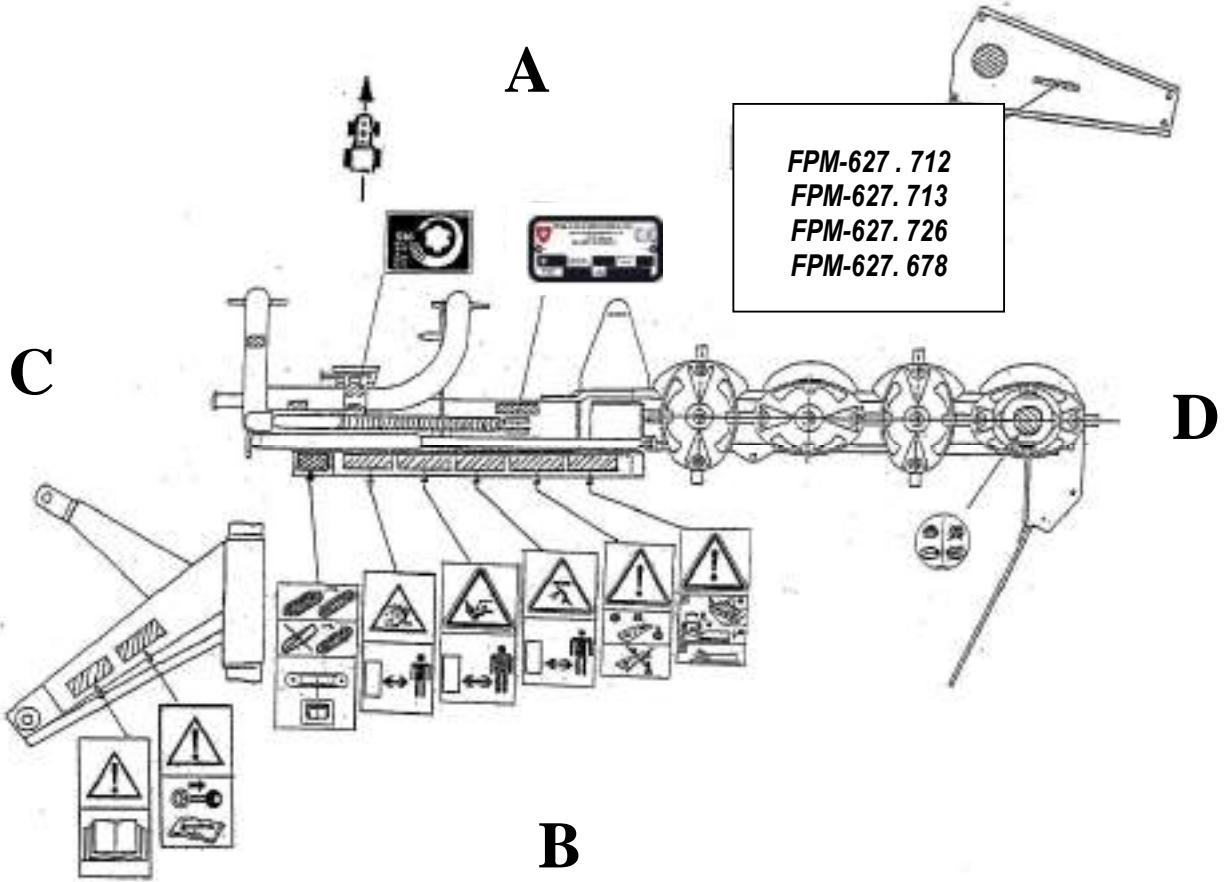

1		
	BEFORE WORKING WITH THE MACHINE, READ THE INSTRUCTIONS CAREFULLY AND OBSERVE THE WARNINGS.	BEFORE PERFORMING ADJUSTMENTS, LUBRICATING OR CLEANING THE MACHINE, TURN OFF THE TRACTOR, REMOVE THE KEY AND WAIT UNTIL ALL MOVING PART HAVE COME TO A STOP.

WARNING LABELS

FPM Boljevac

3



ROTATING PARTS! HAZARD OF EJECTION OF OBJECTS FROM THE GROUND. KEEP AWAY FROM THE MACHINE FOR YOUR OWN SAFETY.

4



ROTATING PARTS! KEEP HANDS, FEET, AND CLOTHING AWAY FROM THE MACHINE MOVING PARTS DURING TRACTOR

5

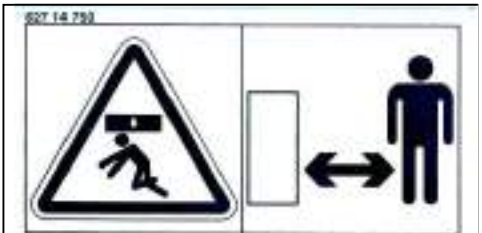

NEVER STAND OR WALK UNDER THE RAISED CUTTING UNIT.

6



ALWAYS USE ORIGINAL PARTS FROM FPM AGROMEHANIKA BOLJEVAC TO ENSURE PROPER OPERATION OF YOUR MOWER.

7



PRIOR TO DETACHING THE MACHINE FROM THE TRACTOR:

1. LOWER THE CUTTING UNIT IN THE HORIZONTAL POSITION.
2. PUT THE LOCK ON THE PROVIDED LOCATION.
3. LOWER THE MOWER TO THE GROUND.

THE MOWER MUST BE PARKED WITH THE CUTTING UNIT IN HORIZONTAL POSITION (B).

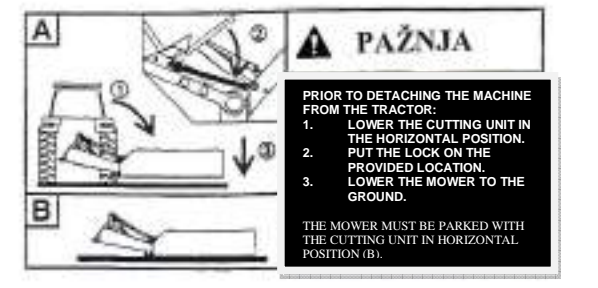
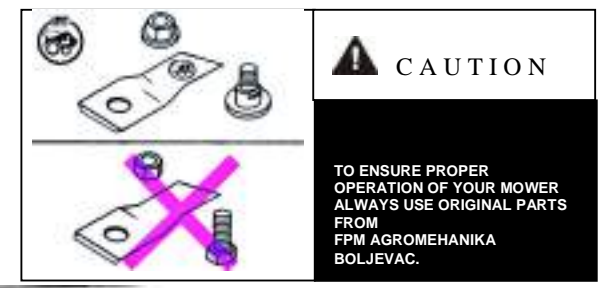
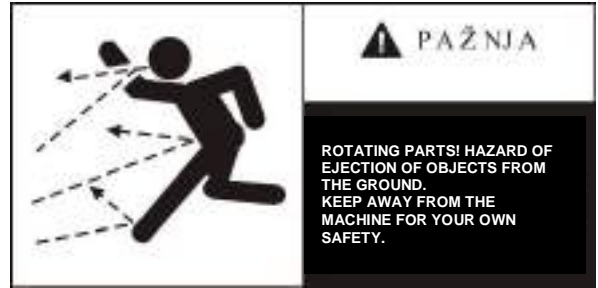

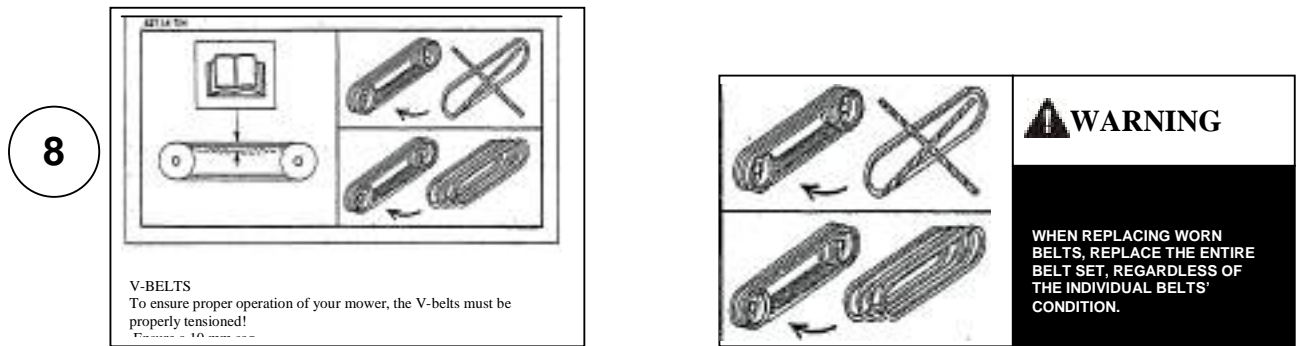

The mower is identified by the nameplate (label no. 2) containing the following numbers:

- The field marked »Z« contains the occupational safety certificate number.
- The field marked »MASA/WEIGHT« contains the product weight information.
- The field marked »GODINA/YEAR« contains the year of manufacture (last two digits) information.
- The field marked »SERIJA/TYPE« -contains the series and commercial designation information.
- The field marked »№« contains the mower number information, comprising nine digits with the following meaning:
 - first digit — year of manufacture
 - second and third digit — manufacturer code
 - remaining six digits — product number from the day of production start.

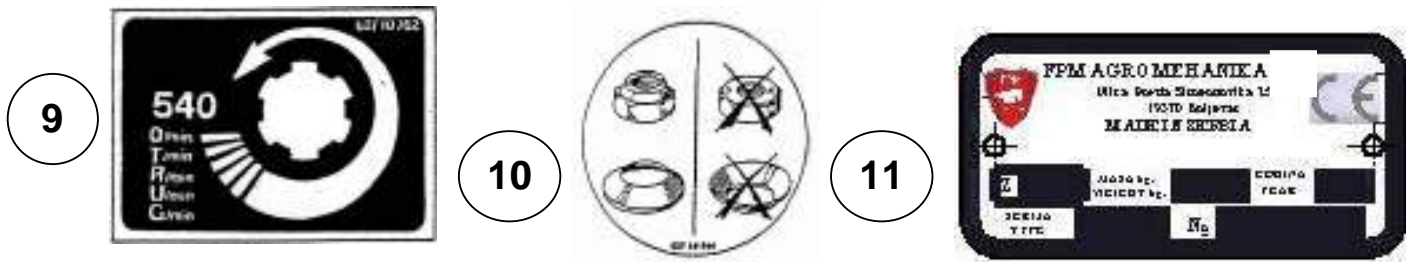

FPM-627.712 ; FPM- 627.713
FPM-627.726; FPM-627.678

INFORMATION FOR READING THE INSTRUCTIONS CORRECTLY

FPM Boljevac

In this manual, “left” and “right” corresponds to the direction of motion.

A – Front end
B – Rear end
C – Left side
D – Right side
(the markings are specified on the page 10 on the label figure).

Metric thread is used for assembly. Tighten all screws during the installation.

Each figure uses symbols showing the installation location.

Read the content carefully in order to assemble the mower properly.

ROTARY MOWER PACKAGE

FPM Boljevac



Rotary mowers with 3, 4, and 5 discs FPM 627 712, FPM 627 713 i FPM 627 726/678 are shipped with the cutting unit attached to the main frame, and packed in a wooden box. Loose items are not attached, but packed separately and placed into wooden boxes.



FPM 627 712

FPM 627 726/FPM 627 678

FPM 627 713

a x b x c = 1650 x 860 x 1950

a x b x c = 1625 x 800 x 2000

a x b x c = 1650 x 800 x 2300



ATTENTION: THIS SYMBOL IS USED TO WARN YOU ABOUT YOUR PERSONAL SAFETY. BE CAREFUL!

MOWER LABELS			
	FPM 627 712/712MPS	FPM 627 726/678	FPM 627 713
No. of discs	3	4	5
Swath width	1.3m	2.10 m	2.1m
Tractor operating speed	16 kmph or above		
Performance	2.0ha/h	2.5ha/h	3.2ha/h
Required tractor output shaft power	18 KW (24.5 HP)	21 KW (29 HP)	25 KW (34 HP)
Cutting discs no. of revolutions (for 540 min⁻¹ tractor shaft)	3000 min⁻¹		
Weight	215 kg	355 kg	385 kg
Cutting unit lifting device	Hydraulic	hydraulic/mechanic	hydraulic
Threads	metric		
Transport position width	0.25 m above the tractor width		

GENERAL INFORMATION

Rotary mowers FPM 627 712,i FPM 627 726/678, and FPM 627 713 are a range of disc mowers with lower drive and three-point linkage. They are attached to the category I and II tractors (according to ISO 730/I and II) with an output shaft with six grooves and no. of revolutions $n = 540 \text{ min}^{-1}$.

For FPM 627 712 and FPM 627 726/678 mower ranges, the attachment points for lower linkages are welded on the frame.

The attachment points for the FPM 627 713 mower (A; Fig. 1) are mountable and secured with spring pins (6x45) (B).from detaching. This enables adjustment of the attachment points according to the tractor module and wheel track, and use of intermediate sleeves, if necessary.

For actuation of a three-disc mower, a minimum of 18 kW (24.5 HP) tractor power is required; for FPM 627 726, and FPM 627 678four-disc mowers, a minimum of 21 KW (30 PS) tractor power is required, and for five-disc mowers, a minimum of 25 KW (35 PS) tractor power is required. Insufficient power may cause

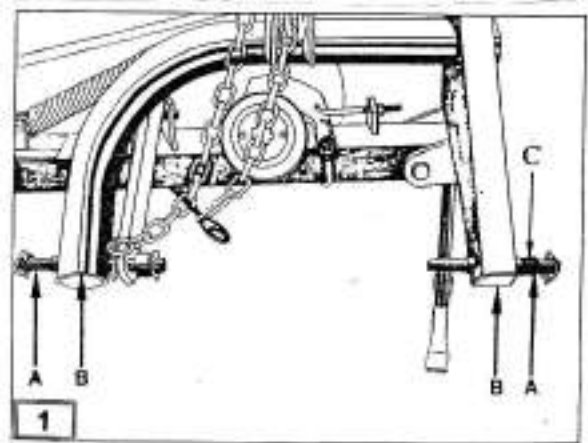

CAUTION: NEVER USE THE MOWER ON ROCKY TERRAIN.

For easier transport of FPM 627 726678 and FPM 627 713 rotary mowers, few parts and assemblies have been removed in order to minimize the size. To properly assemble the mower, proceed as follows:

1. - To mount the support frame to the cutting unit

- Secure the free yoke connecting the support frame and the step-up gear unit with two self-locking nut (A) (Abb. 2). In order to ensure safe support of the cutting unit, tighten the nuts (A) with a torque of 13.5 daNm.

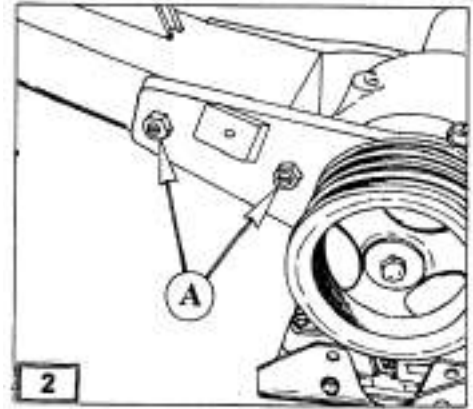

ATTENTION:

For your personal safety, prevent the frame from overturning and turning during assembly.



2. - To assemble the pulley guard and V-belts

- Mount the front guard side (A; Fig. 4) and attach it using the screws (B) and tightening torque of 5 daNm, **Four-disc mowers have pulley with three grooves for V-belts.**
- Clean the pulley opening (A; Fig. 3) and slide it onto the shaft of the step-up gear unit (Fig. 4, pos. D). Secure it with the provided washer and nut. Insert the protrusion (B; Fig. 3) of the pulley hub towards the step-up gear unit.

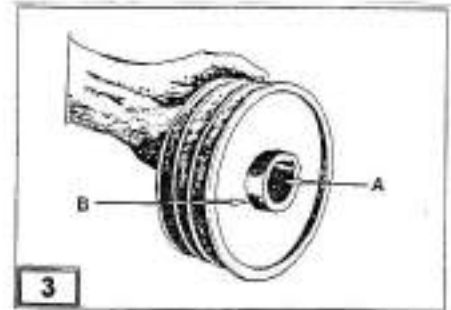

- Place the V-belts (D) onto the pulleys; loosen the nuts (A) while simultaneously tightening the nut (D) (Fig. 5). The V-belts are properly tensioned, if maximum sag of 10 mm is achieved when 3.5 daNm force is applied. When tensioning the belts, ensure that the pulley housing is sliding on the guide (A; Fig. 5a). When tensioning force is achieved, tighten the pulley house using the nuts (A; Fig. 5) to complete the assembly.

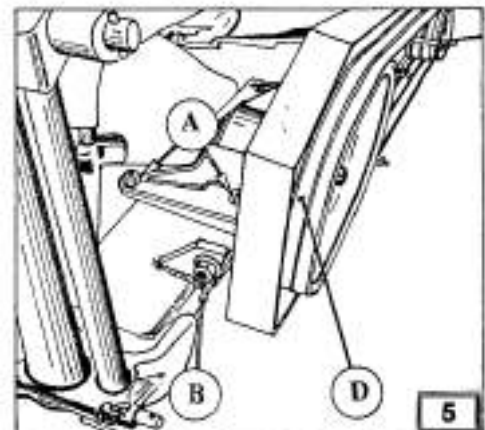
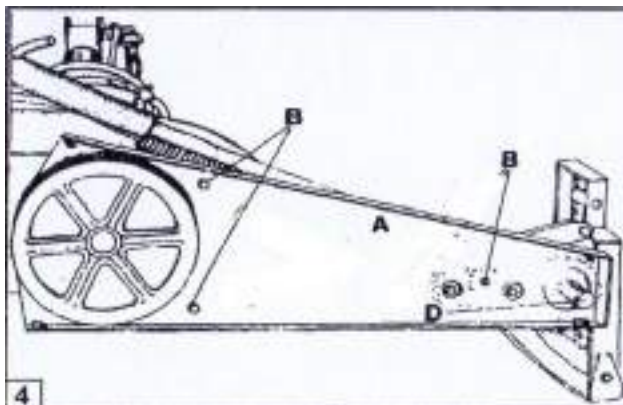

- Mount the read guard end (I; Fig. 6), and attach it with six M8x20 screws (B) applying a 5 daNm torque.

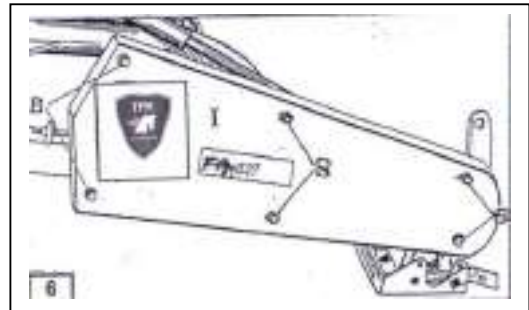
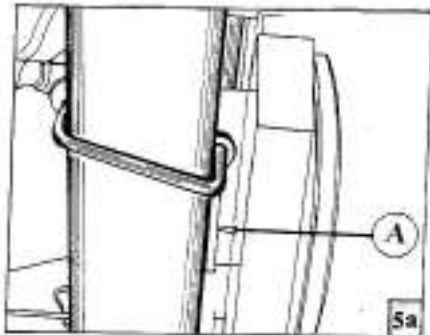

3. - To assemble the balancing rod

- Fasten the balancing rod (L; Fig. 8) to the attachment point on the frame as shown (Fig. 8).

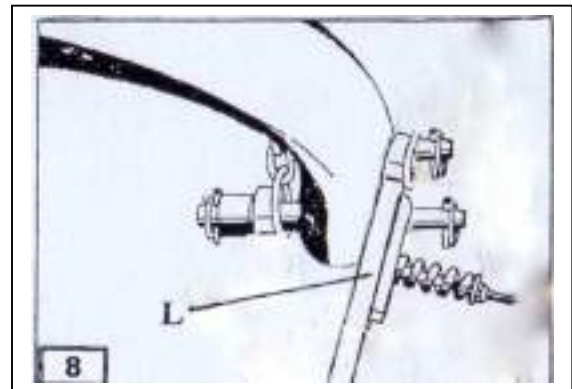
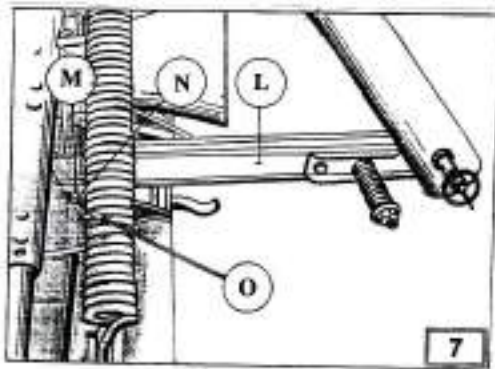

4. - To mount the cover supports and hydraulic cylinder yoke

Attach the support frame (D; Fig. 11) to the step-up gear unit using two M12x35 screws (F) and two M12x45 screws as shown (Fig. 11) applying a 14 daNm torque.

Attach the hydraulic cylinder yoke (A) as shown in Fig. 14 and secure two bolts using the spring pins (F), four \varnothing 5x30 pieces.

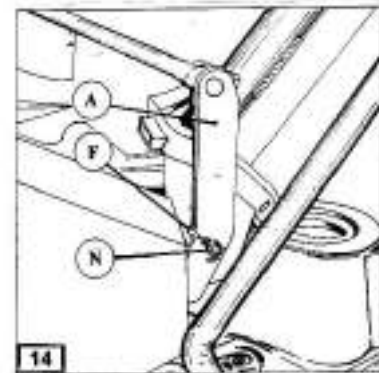
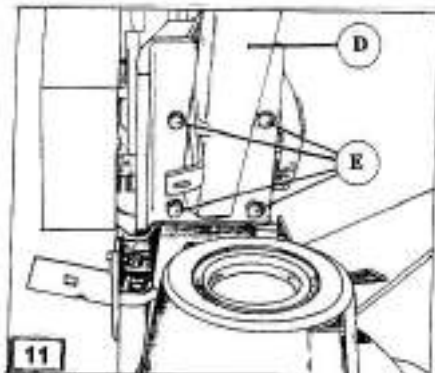

- To mount the mouldboard

- The entire mouldboard is mounted by attaching the plate (U) to the mouldboard support (R) on three places (O) using the M8x18 screw, flat washer (Y), spring washer (V), and nut (W) as shown in Fig. 16. Make sure to adjust the mouldboard during assembly by providing enough space between the cutting disc and the plate to ensure undisturbed passage of the

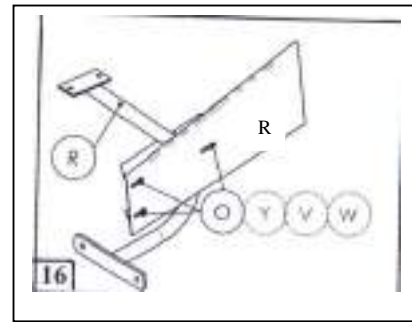

6. - To mount the canvas cover supports

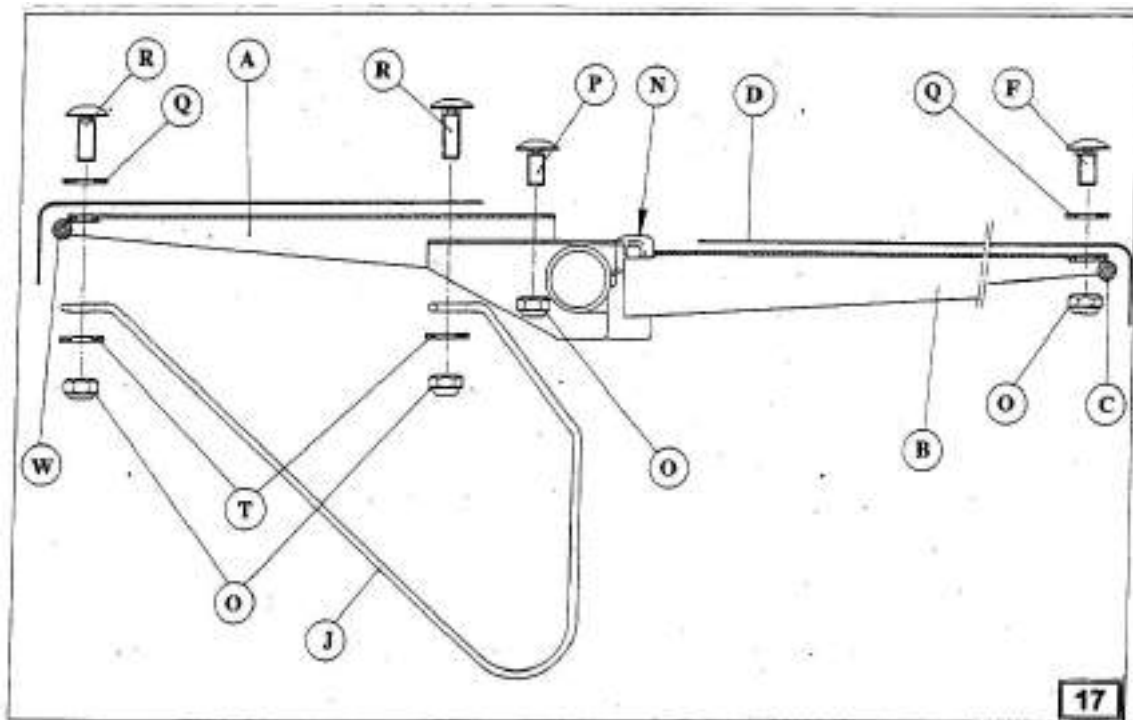

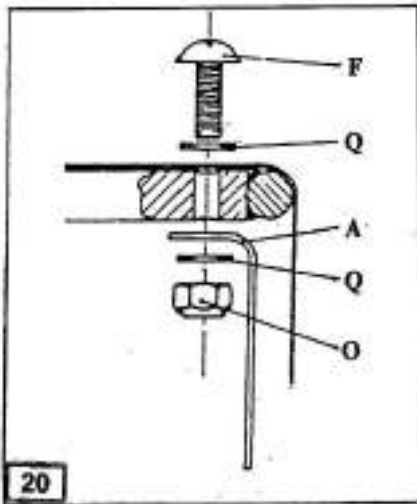
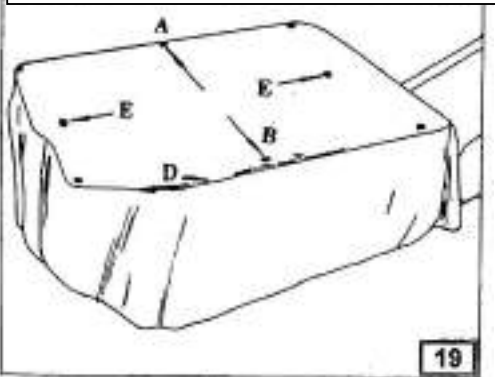
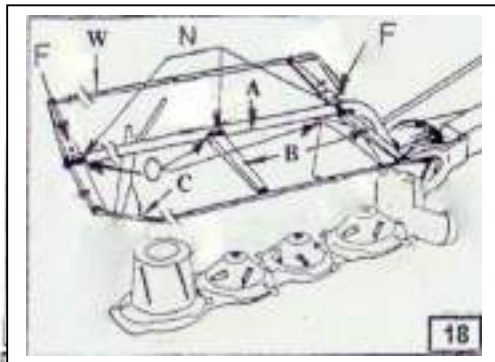

- Connect the front half of the frame (C) using the M10x25 screws (F) to the corresponding brackets (B) using the flat and plastic washers (Q; $\varnothing 10$), M10 nuts (O) as shown in Fig. 17.
- Attach the assembled frame half to the openings (N) using the M10x75 screws and secure it using the M10 self-locking nuts. Tighten the nuts to enable the protective frame to rotate freely (see Fig. 17 and 18).
- Subsequently, connect the rear half of the frame (W) using the M10x25 screws (F) to the corresponding brackets (A) using the flat and plastic washers (Q; $\varnothing 10$), M10 nuts (O) as shown in Fig. 18.
- Fasten the canvas cover (D; Fig. 19) on the places shown (E) using the straps. On the inner side, affix the clamped strap in the back (A) and the perforated strap on the front moving end on the inner side at the location B (Fig. 19).
- Make sure to properly fasten the canvas cover to the frame; place the plastic washer (D) on the cover, and secure the flat washer and the screw (F), and the nut (O) on top of that (Fig. 20). This figure shows how to attach the perforated straps (A) and clamped straps (B).
- Install the support (J) on the end of the protective frame and secure it using two M10x30 screws (R), two $\varnothing 10$ washers (T), and two M10 self-locking nuts (O) as shown in Fig. 17.
- Figure 21 shows how to fold the canvas cover for transport. After folding the cover, secure the front and rear ends using the straps (A and B) shown in Fig. 19 to prepare the mower for transport.

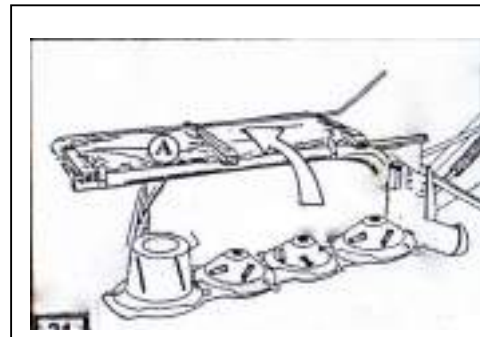

ATTENTION:

ENSURE THAT THE PLASTIC COVER IS ALWAYS INSTALLED ON THE FRAME AND LOWERED IN THE OPERATING POSITION WHEN WORKING WITH THE MOWER.



Hydraulic installation

A-- When attaching the mower to the tractors with a control distributor for external hydraulic, attach the hydraulic cylinder lines to the hydraulic outlet.

B - -For attaching the mower to the tractors manufactured by IMT - BEOGRAD:

- On the gearbox housing, loosen two screws (A) and remove the cover (B) (Fig. 22). Keep the cover and the screws in a clean and safe place.

WARNING: CAREFULLY LIFT THE COVER UP TO MAKE SURE THAT THE OIL SUPPLY PIPE DOES NOT GET DISCONNECTED.

- Remove the pipe and rubber gasket from the cover and connect it to the corresponding opening on the distributor.
- Carefully place the distributor (D) on the gearbox housing, and secure it using two M12x35 screws (Fig. 23). The screws are supplied with the distributor. Attach the hydraulic cylinder line to the end of the curved distributor pipe.

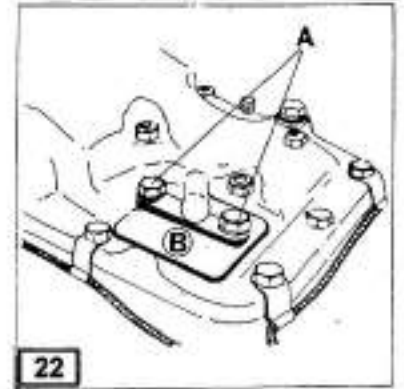

WARNING: IF YOU FAILED TO PROPERLY PLACE THE GASKET IN THE OIL SUPPLY PIPE, THE HYDRAULIC INSTALLATION WILL NOT WORK. REPEAT ALL OF THE ABOVE STEPS MORE CAREFULLY.

- Put the lever (C) on the distributor (Fig. 23) in the operating position for the hydraulic cylinder to raise the cutting unit. Putting the lever (C) in neutral position blocks lifting of the cutting unit.

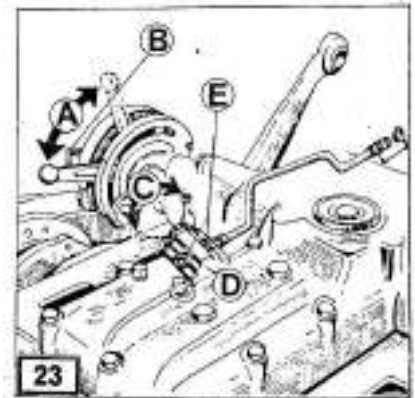

WARNING: WHEN THE DISTRIBUTOR LEVER IS IN THE OPERATING POSITION, TRACTOR LINKAGES DO NOT WORK.

- Use the lever (A; Fig. 23) to put the linkages in the operating position (and put the distributor lever in the neutral).

SUPPLY OF THE MOWER HYDRAULIC INSTALLATION

- The hydraulic cylinder is supplied from the tractor installation. The lever (A; Fig. 24) regulates the response speed for lowering the hydraulic (lower quadrant in the FAST sector); secure the lever in the desired position using the nut (C).

By moving the lever (B) up and above the two points, the oil is pushed into the machinery installation, and by lowering the lever, the oil is returned to the tractor housing.

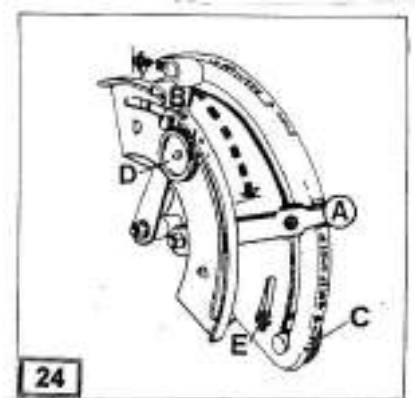

ATTENTION: ENSURE THAT NOBODY STANDS IN THE WAY OF THE CUTTING UNIT.

JOINT COUPLING — PTO SHAFT

FPM Boljevac

It is extremely important to properly adjust the PTO shaft for attaching the mower to the tractor. Never allow the universal joints to get jammed when the machine is raised in the topmost or lowered in the bottommost position. The PTO shaft has a star ratchet clutch. Make sure to install the star ratchet clutch on the mower side to enable operation of the mower.

If you determine that the PTO shaft is longer and therefore impossible to attach to the tractor, it must be cut to length. The following pictures show how to cut the PTO shaft to length.

1.- Attach one PTO shaft half to the tractor and to the mower while keeping the other halves near each other.

Keep adjusting the tractor and mower position until a 10 mm length is identified, and mark this length on the guard, see Fig. 25.

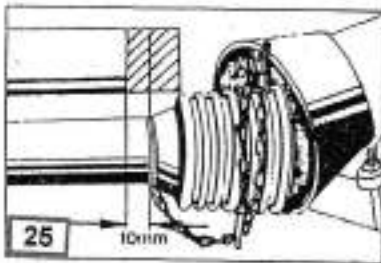

2.- Cut the guard, see Fig. 26.



3.- Cut the section tube, Fig. 27. No further modifications to the guard or the section tube are allowed.

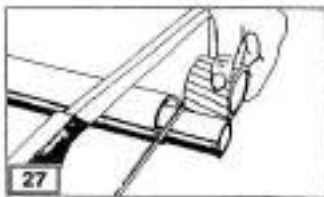

NOTICE: FAILURE TO OBSERVE THE BASIC REQUIREMENTS FOR THE PTO SHAFT OPERATION MAY LEAD TO BREAKAGE OF THE PTO SHAFT OR DAMAGE TO THE ROTARY MOWER.



4.- Remove any sharp edges, Figure 28.

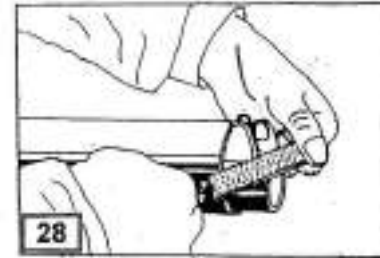

5.- Clean and apply grease, Figure 29. Attach the PTO shaft

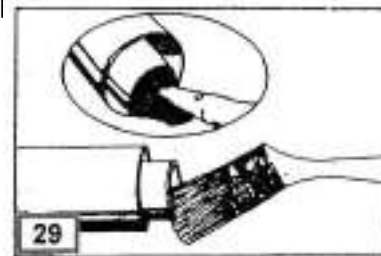

6.- Never remove or allow PTO shaft guard to rotate. Hang the guard chain on the PTO shaft guard, Fig. 30.

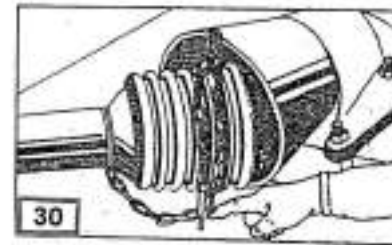

7.- The PTO shaft may not operate under a too large angle (max. 10 deg.)° Figure 31.

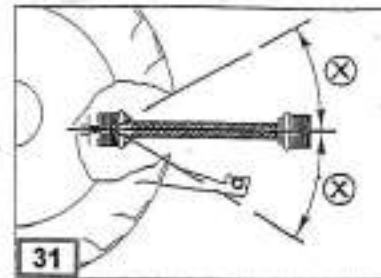

ATTACHING THE MOWER TO THE TRACTOR FPM Boljevac

- In order to ensure proper operation, attach the mower to the linkages of a tractor with 1.32 m wheel track as shown in Fig. 32. For tractors with 1.5 m wheel track, the mower is attached acc. to Fig. 33. For tractors with 1.65 m wheel track, arrange the linkages as shown in Fig. 34. All three above cases have a min. 5 cm "clearance" (shown as A) in common, enabling the operator to use the entire swath width of the cutting unit.

NOTE: CHECK WHETHER THE TENSIONING CHAIN (C) ALLOWS THE CUTTING UNIT TO TAKE PROPER OPERATING POSITION.

To perform the attaching operation:

- 1.- Remove the paint from the mower trunnions.
- 2.- Reverse the tractor slowly, lower the lower linkages using the hydraulic controls until they reach the height of the centre line of the mower attachment points, and proceed to attaching and locking the linkages as shown under (A) in Fig. 35.
- 3.- Attach the upper linkage (B), Fig. 35, using the bolt (C) to the attachment point on the top of the support frame, and depending on the tractor category insert the tapered, i.e. wider bolt end and secure it using the provided lock.

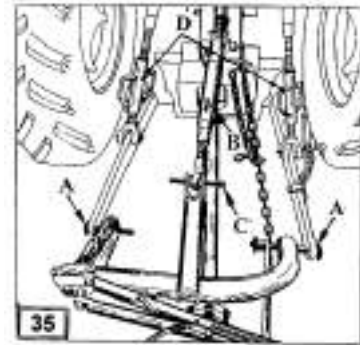
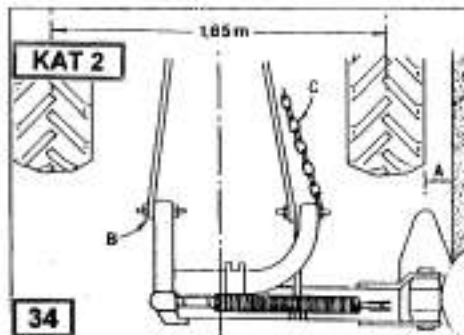
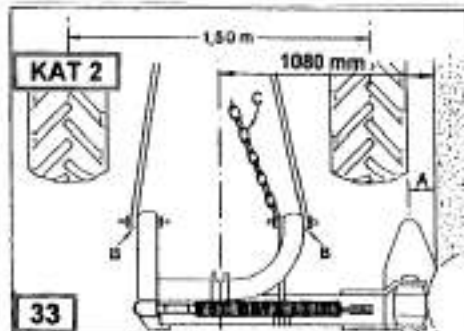
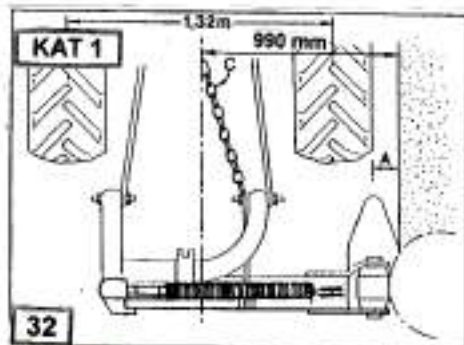

- 4.- After completing the above operations, raise the mower from the ground using the hydraulic to the necessary transport height.
- 5.- For mower safety during transport, remove the lock (A), Fig. 36, and turn the support foot (B) upward, re-secure and re-lock it with the lock (A) to prepare the mower for transport.

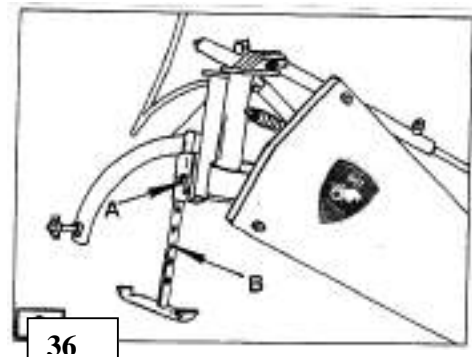

For transporting the mower on public roads or from one field to another, remember and do the following:

1. Switch off the tractor output shaft and wait until all moving parts have come to a stop.
2. Raise the mower to the height required for transport using the hydraulic, remove the lock (A; Fig. 36) and turn the support foot (B) upward, then secure it with the lock (A) again to prepare the mower for transport.

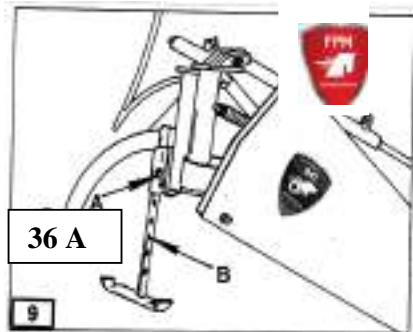

3. Reposition the locking pin (A; Fig. 37) on the floating rod in the transport position (see label drawing B), and secure it with the lock to prevent the rod from floating.

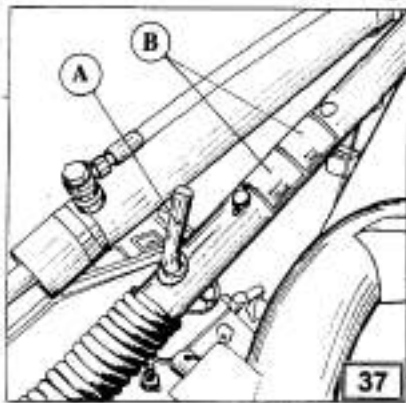

4. Fold the front end of the canvas cover (A) backwards (see arrow), Fig. 38, and fasten it using the provided straps in

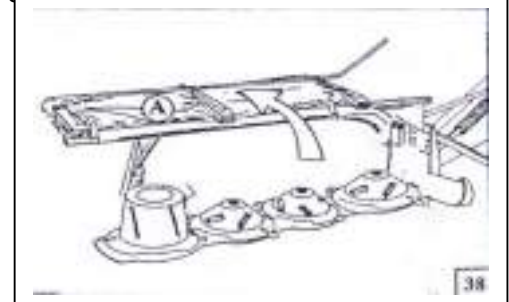

5. Fasten the support frame (T) with the lock (L) to secure the mower for transport.

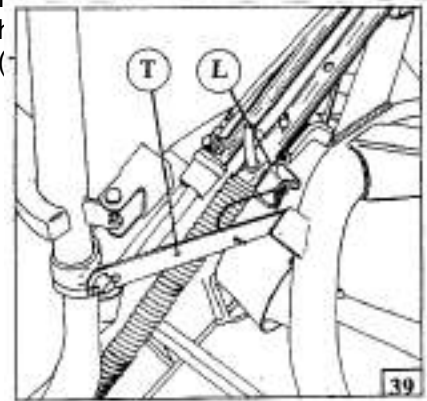

6. Lower the drawbar from the neutral position, connect it (T) with the support frame and secure it with a lock (L: Fig. 39) to prepare the mower for transport.



ATTENTION:

When transporting the rotary mower, the drawbar (T; Fig. 39) must be in the attached in order to ensure safe and secure transport.



ATTENTION: PRIOR TO TRANSPORTING THE ROTARY MOWER, ENSURE THAT THE MOWER IS SECURED FOR TRANSPORT AND THAT ROAD SAFETY REGULATIONS ARE COMPLIED WITH.

1. Place the locking pin (A; Fig. 40) in the operating position. This releases the spring enabling the cutting unit to copy the terrain properly.

WARNING: FOR REPOSITIONING THE LOCKING PIN, THE CUTTING UNIT MUST BE RAISED IN THE TRANSPORT POSITION.

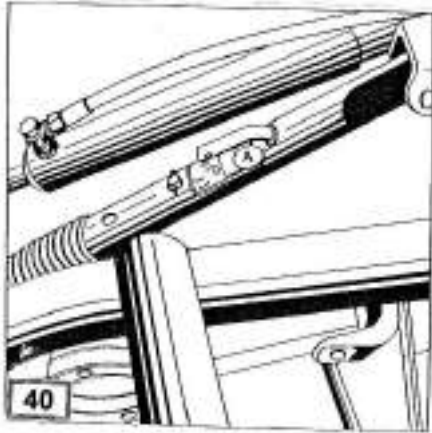

2. Detach the transport position lever (T) from the mower support frame and attach it to the frame (canvas cover support) securing it with the provided spring lock (L; Fig. 41).

! ATTENTION: PROCEED VERY FULLY WHEN LOWERING THE CUTTING UNIT; ENSURE THAT NOBODY IS STANDING IN THE WAY OF THE CUTTING UNIT BEING LOWERED.

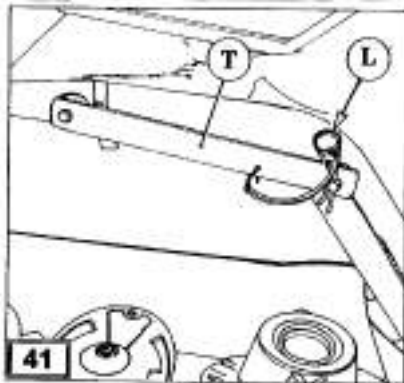

3. Lower the cutting unit in the operating position using the hydraulic cylinder.
4. Use the tractor linkages to adjust the mower so that the attachment point (A) centres are approx. 450 mm from the ground (Fig. 42).

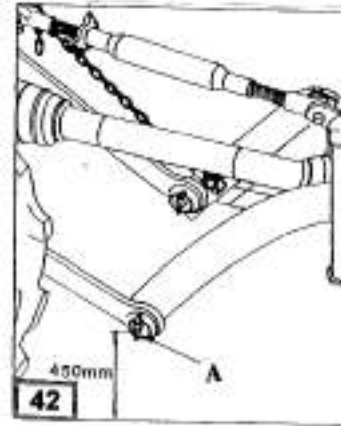

5. Attach the chain (D) in the slot on the tractor tenterhook (A) as shown in Fig. 43. Lower the tractor linkages fully to complete adjusting the height.

The adjustment is correct if the:

- cutting unit is resting on the ground
- chain is fastened and tensioned
- distance between the attachment points and the ground is around 400

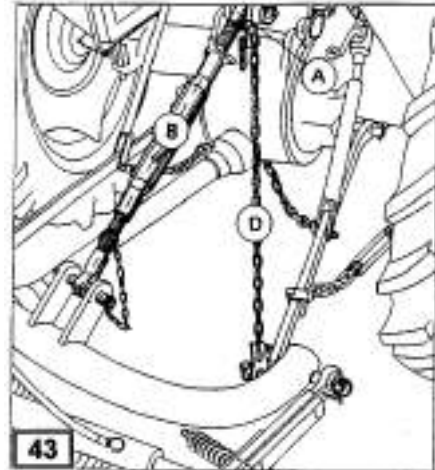

Controlling the hydraulic cylinder is very important for proper mower operation. Perform the adjustments during operation to make the work easier and increase work performance.

The cutting height is adjusted by turning the entire cutting unit along its roll axis. This is performed by shortening or extending the upper linkage (B; Fig. 43 and 44). Always perform the adjustment operation carefully to ensure a clean cut (Fig. 44).

NOTICE: IT IS EXTREMELY DANGEROUS NOT TO TURN THE CUTTING UNIT WHEN ADJUSTING THE CUTTING HEIGHT SO THAT THE CUTTERS HIT THE GROUND DURING OPERATION. THIS WILL DAMAGE THEM QUICKLY AND SMASH THE ROOTS.

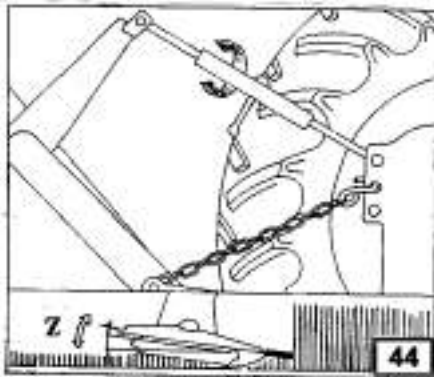

If the cutting unit hits a hidden obstacle during operation, safety device (R) triggers and detaches the cutting unit, Fig. 45.

TO CONTINUE MOWING, STOP THE TRACTOR AND SWITCH THE OUTPUT SHAFT OFF.

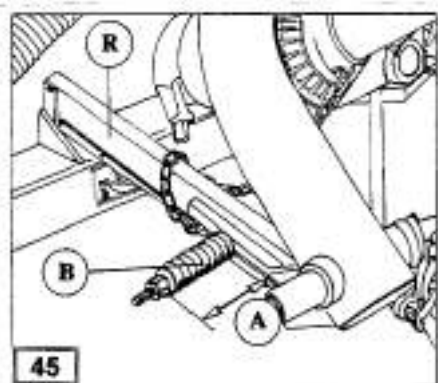

Reverse the tractor slightly and raise the mower using the linkages. Using a swinging motion, draw the cutting unit towards the tractor to reset the safety device in its original (operating) position.

WARNING: Check the safety device box for proper lubrication. If necessary, apply grease to all telescoping parts.

The safety device is factory-adjusted for normal operating conditions and is triggered only when the cutting unit collides with hidden (solid) obstacles on the ground. For four-disc mowers, the spring (B) has a size (A) which is 102 mm (Fig. 45).

Should the adjustment of the safety device at the user's location be necessary in order to adapt it to the local soil conditions, the main principle is to adjust the safety device spring not to trigger under normal working conditions.

WARNING: DO NOT OVERTIGHTEN THE SPRING.



ATTENTION: ONLY OPERATE THE MOWER WHEN THE PLASTIC COVER IS INSTALLED. NEVER LIFT THE FRONT END OF THE PLASTIC COVER.

After lowering the cutting unit from the transport in the operating position, let the cutting unit shaft rotate for a while at low revolutions to allow the oil to distribute inside of the cutting unit housing.

Prior to beginning work, increase the revolutions to 540 min⁻¹.

It is extremely important that the mower shaft operates at required rpm in order to ensure satisfactory work quality and prevent clogging. Adapt the forward movement speed to the soil conditions.

The mowing operation may be performed continuously, i.e. without interruptions on headlands turns and raising the cutting unit from the ground, since the cutting unit is not getting clogged like usual mowers when driving over the mowed material, and thanks to the cutting discs' special shape, the mowed material is not shred further.



CAUTION: PRIOR TO BEGINNING WORK, REMOVE ALL STONES AND HIDDEN OBSTACLES FROM THE FIELD.

Take special precautions when working on uneven ground. Adjust the mower in such a way as to minimize the risk of hitting foreign objects with the cutters to avoid blunting them.

1. Tilt the cutting unit at a backward angle using the upper linkage lever (B; Fig. 43) to increase the cutting height.
2. Adjust the cutting speed to the soil conditions.

3. Ensure that the cutter turns when the cutting edge hits an obstacle.
4. Turn the cutter (using appropriate tools).

Plastic guard collects foreign objects bouncing off the cutters and cutting blades and helps prevent injuries to the operator.



CAUTION: NEVER OPERATE THE MOWER WITHOUT THE PLASTIC GUARD INSTALLED. LOWER THE GUARD FRONT END IN THE OPERATING POSITION DURING WORK.

IMPORTANT: It is very important to lubricate the transmission components in order to comply with the requirements of heavy-duty operation. The easiest way to discharge the oil is immediately after finishing work when the oil is still warm and the sediment has not yet settled. Replace the oil after mowing a 100 ha area, or once a year at a minimum.

For replacement, use:

Manufacturer name	Oil designation
Fabrika maziva Kruševac	FAMHIPO 90 EP
Rafinerija Beograd	HIPOL B
SHELL	E.P.80

or other manufacturers' oils compliant with the specifications.

- MIL - L 21 05 B
- API Service GL 5
- JUS B. H3. 303 MP - 5

SIDE-MOUNTED STEP-UP GEAR UNIT

To refill the unit, unscrew the oil filler plug B, Fig. 21. Oil quantity is specified in the below table.

STEP-UP GEAR UNIT CAPACITY

Litres: 1.7 l

CUTTING UNIT HOUSING

To refill the cutting unit with oil, unscrew the plug A, Fig. 22.

WARNING: To refill the cutting unit with oil, bring in in the vertical transport position.

CUTTING UNIT CAPACITY

Mower series	Litres
FPM 627 712	2.0
FPM 627 716/678	2.7
FPM 627 713	3.5

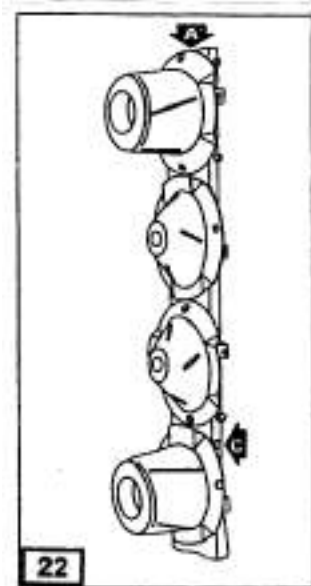
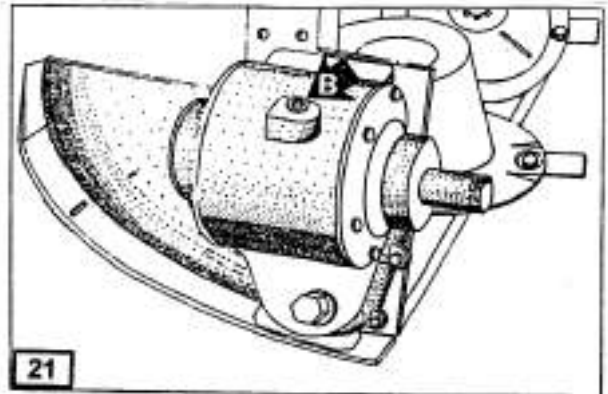

The plug C, Fig. 22, is used to control the oil level.

WARNING: READ AND MEMORIZE THE ABOVE SPECIFICATIONS CAREFULLY. CHECK THE STEP-UP GEAR UNIT, I.E. THE CUTTING UNIT HOUSING FOR EXCESS HEAT BUILDUP DURING OPERATION BY TOUCHING IT WITH YOUR RIGHT PALM. NORMAL OPERATING TEMPERATURE IS ABOUT 90 °C.

WARNING: IT IS RECOMMENDED TO REDUCE THE QUANTITY OF OIL IN THE CUTTING UNIT DRAWING A POSITIVE OR NEGATIVE ANGLE DURING OPERATION WITH THE HORIZONTAL LINE BY ABOUT 25 PER CENT.

IT IS ALSO RECOMMENDED TO HOLD THE CUTTING UNIT HORIZONTALLY FOR A FEW MINUTES EVERY HALF AN HOUR.

LUBRICATION

Inspect the lubrication condition of all places with installed grease nipples and other glide surfaces.

Good lubrication level should be achieved every eight hours of operation. Prior to lubrication, remove dirt and dust from the surfaces. Lubricate rotating and articulated parts every fifty hours. Lubricate all telescoping parts as needed.

1. Front joint grease nipple.
- every 8 hours
2. Rotating guard part on the front PTO shaft end.
- every 40 hours
3. Inner telescopic tube part.
- every 20 hours
4. Rotating guard part on the rear PTO shaft end.
- every 40 hours
5. Rear joint grease nipple.
- every 8 hours
6. Locking bolt on the front and rear end.
- every 40 hours
7. Clean all shaft parts if the shaft was out of use for a prolonged period of time.

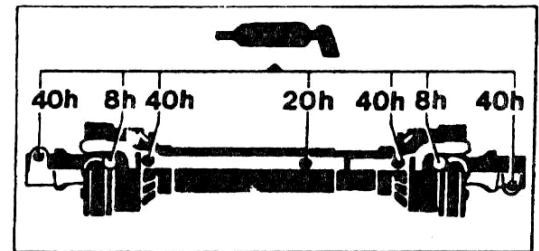

Figure 23.

By following this lubrication chart, you will achieve longer service life of the shaft. Careful maintenance prevents malfunctions resulting from heating or damage of the bearings, or increased axial force. Lubricate the PTO shaft on indicated places using high-quality lubricating grease.

GREASE ALL ROTATING, SLIDING, AND ARTICULATED JOINTS ON THE MOWER FRAME.



NOTICE: ALWAYS KEEP IN MIND TO USE THE GREASE WITH REQUIRED QUALITY IN ORDER TO PREVENT UNINTENTIONAL DAMAGES TO THE MACHINE. BY PROPER AND REGULAR LUBRICATION, UNINTERRUPTED AND SAFE MOWER OPERATION IS ENSURED.

CAUTION: Remove all objects when adjusting your mower. Foreign objects and parts may be ejected in the direction of individual standing by.

DISCS AND CUTTERS

The discs, cutters and cutter brackets are of high-quality. The cutters and cutter brackets are made from special alloyed steel which is tough and wear-resistant and have long service life.

Any worn or damaged parts must be replaced with original parts from FPM Boljevac to ensure high quality and precise assembly.

! DANGER: USE ONLY ORIGINAL PARTS MANUFACTURED BY FPM AGROMEHANIKA BOLJEVAC.

After long use, the cutting edges are blunted and do not provide satisfactory cutting quality. Blunt edges require increased drive power, and leave the stalk edges uneven and rough.

Before replacement, remove soil and dirt from the cutter, cutter bracket, and nut as shown under A on the sketch 24. Loosen the nut and knock the cutter bracket out from its bearing.

Two cutters are installed on each cutting disc rotating clockwise with the adjacent disc rotating counter-clockwise.

After determining that the cutter edges are blunt, interchange the cutters on the adjacent discs (each cutter has two blades).

As long as there is a tempered blade, the cutters can be sharpened while maintaining the required blade angle.



ATTENTION: Prior to performing any adjustments or configurations to the machine, switch off both the PTO shaft and the tractor engine.

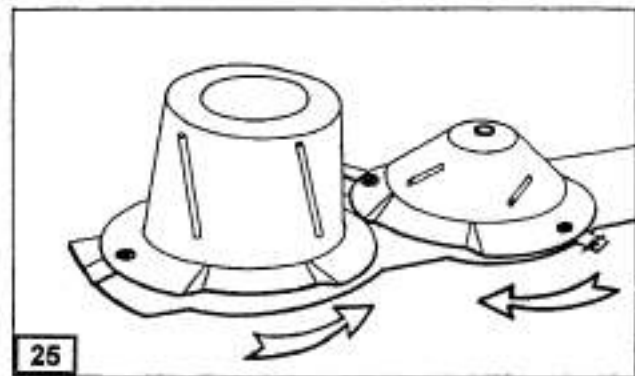
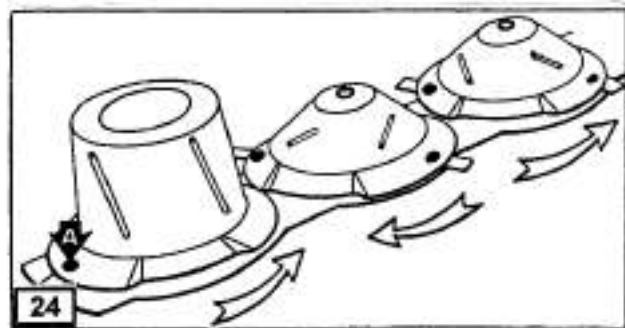

In case of more extensive damage, replace the cutter with a new one from the set supplied with the mower.



ATTENTION: ALWAYS REPLACE DAMAGED CUTTERS AND NEVER TRY TO STRAIGHTEN BENT CUTTERS.

Adjust all discs so that the cutter centre line draw a 90 degree angle.

V-BELTS

The V-belts must be properly tensioned in order to prevent excess sliding. Insufficiently tensioned V-belts will cause poor performance of the cutting unit, as well as premature damage and tears (see Section 2 on page 15).

To tension the belt, loosen two nuts (A; Fig. 52). Keep tightening the nut (B) until a 9 daN force is achieved, i.e. 10 mm sag between the belts. In doing so, make sure that the housing is sitting properly on the frame. Finally, retighten the nuts (A).

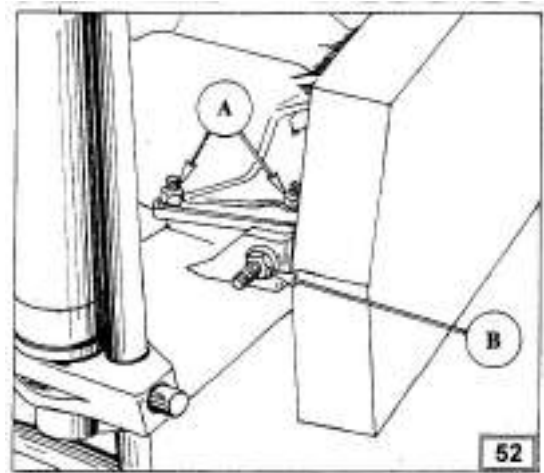

WARNING: IT IS IMPORTANT TO CHECK THE TENSION OF THE BELTS AND TO PROPERLY TENSION THEM. IN PARTICULAR, THESE OPERATIONS MUST BE PERFORMED 30 MINUTES AFTER COMMISSIONING.

WHEN REPLACING WORN BELTS, REPLACE THE ENTIRE BELT SET, REGARDLESS OF THE INDIVIDUAL BELTS' CONDITION.



CAUTION: CHECK THE TENSION OF ALL SCREWS AND NUTS REGULARLY, IN PARTICULAR IN THE CUTTING UNIT AREA WHERE DISCS AND CUTTERS ARE LOCATED.



CAUTION

1. IT IS YOUR RESPONSIBILITY TO PROTECT YOUR MOWER. REPLACE ALL WORN OR DAMAGED PARTS WITH ORIGINAL PARTS FROM IMT AGROMEHANIKA AD BOLJEVAC IMMEDIATELY.
2. LUBRICATING, ADJUSTING, CLEANING AND CONFIGURING OPERATIONS MAY ONLY BE PERFORMED WHEN THE TRACTOR AND THE PTO SHAFT ARE SWITCHED OFF.
3. WAIT UNTIL ALL MOVING PARTS HAVE COME TO A STOP TO PROCEED WITH MAINTENANCE.
4. KEEP YOUR HANDS, FEET, AND CLOTHING AWAY FROM THE MOWER'S MOVING PARTS.
5. ALWAYS KEEP THE CONSEQUENCES OF IRRESPONSIBLE AND UNSAFE WORK IN MIND, SINCE THIS MAY CAUSE GRAVE HARM.
6. BEFORE TURNING THE TRACTOR ON AND COMMENCING WORK, ENSURE THAT NO INDIVIDUALS OR ANIMALS ARE IN THE MOWER WORK AREA.



CAUTION: STOP AND THINK! ROTATING PARTS MAY CAUSE SERIOUS BODILY HARM.

To park the mower, proceed as follows:

- Lower the foot (D) from the upper transport position into the support position.
- Using the tractor hydraulic, lower the mower until it is resting on the ground.
- Bring the cutting unit from the vertical transport position in the horizontal position.
- Bring the front end of the canvas cover in the front position.
- Detach the mower from the tractor linkages.
- Remove the male coupling connector (F) of the hydraulic pipe and wrap it around the mower frame.
- Detach the PTO shaft (T) from the tractor output shaft.
- Attach the chain (E) to the PTO shaft and the mower frame, and secure it from unwinding using the hook (C) as shown in Fig. 54.

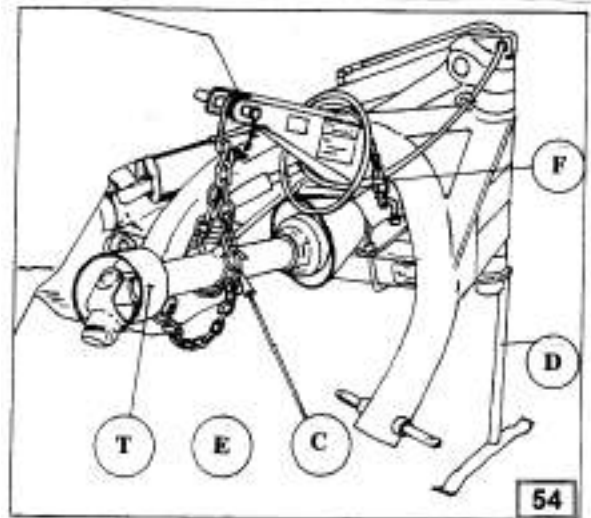

WARNING: BEFORE LOWERING THE CUTTING UNIT PROCEED WITH CAUTION. NOBODY IS ALLOWED TO STAND IN THE WAY OF A LOWERING UNIT.



FOR PERSONAL SAFETY, ALWAYS LEAVE THE MOWER PARKED WITH THE CUTTING UNIT IN THE HORIZONTAL POSITION.

MAINTENANCE TABLE

FPM Boljevac

ISSUE	POSSIBLE CAUSE	CORRECTIVE ACTION
Cutting unit does not float (does not copy the ground)	Support frame not properly adjusted. Trunnions and yokes are getting stuck on the cutting unit.	Adjust the support frame to bring the attachment points to a 400 mm height from the ground and be parallel. Lubricate the trunnions and yokes.
Mower balancing rod keeps unlocking.	Balancing rod spring insufficiently tightened.	Tighten the balancing rod spring (see page 24).
Difficulties adjusting the cutting unit angle.	Tension chain in inappropriate position.	Put the tension chain in appropriate position.
Grass stalks not uniformly cut.	Cutting unit angled too steep. PTO shaft rpm too low. Forward speed too high. Blunt or broken cutter.	Adjust the incline. Work with 540 min ⁻¹ of the PTO shaft. Reduce driving speed. Install a new cutter.
Grass stalks cut too high.	Cutting unit angle not adjusted.	Change the cutting unit angle.
Crop stalks falling forward before cutting is performed.	Wind moving the grass.	Adjust the cutting direction (mowing). Regulate the PTO shaft rpm, increase the forward driving speed.
Excessive wear and tear of the cutters and discs.	Heavy duty working conditions.	Pick appropriate cutters and reinforced discs.
Soil sticking on the front end of the cutting unit.	Working on wet or damp soil.	Adjust the frame height by shortening the chains to the required height.

INSPECTING THE CUTTERS AND CUTTING DISCS

Boljevac

FPM

A) CUTTERS: Before beginning work, inspect them thoroughly. Proper cutting, and good and safe operation depend on properly sharpened cutters.

1. DAMAGED CUTTERS

Very rough, abrasive and damaged edges cause cracks and lead to:

- increased risk of accident
- reduced cutting quality
- risk of damaging the cutting unit

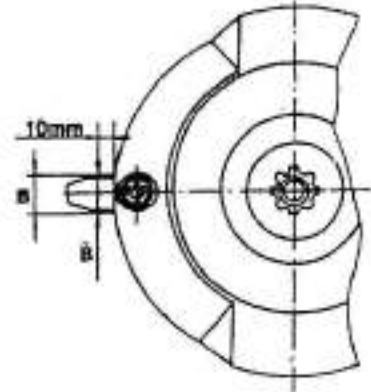

2. WORN OUT CUTTERS

The width (B) of the worn cutter, measured 10 mm from the cutting disc edge, may be at least three quarters of the usual cutter width.

The length of the oval opening (L) on the cutter must be max. 18 mm.

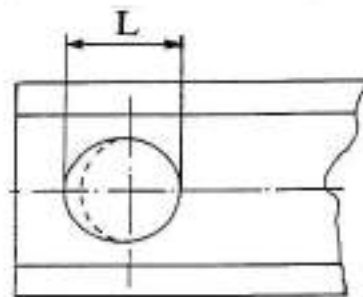

B) CUTTING DISCS: These require regular checks! (in particular, the tightening torque of the screws). The required torque is 7.5 daNm.

- Inspect the discs immediately upon hitting a hidden obstacle.
- Perform an inspection when replacing the cutters.

Always install a cutter pair from FPM AGROMEHANIKA DOO BOLJEVAC to avoid unbalancing the disc.

Perform an inspection before every mowing season.

1. Replace the cutter bracket for safety reasons.

- When visible damages are present.

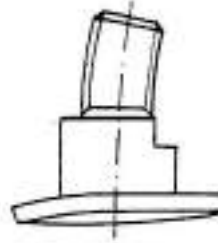

- When the cutting head is abraded up to the cutter contact area.

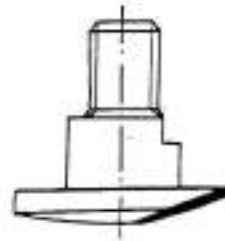

- When the cutter bracket's nominal diameter $D_n = 16$ mm reaches its maximum value on the abraded cutter bracket of $D_n = 13$ mm.

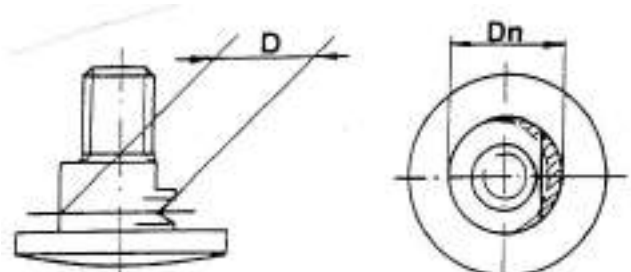

2. Replace the nut.

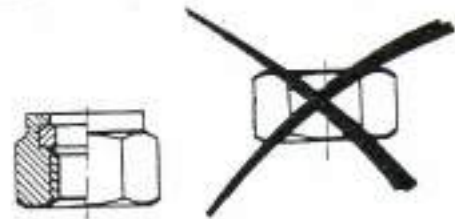

- When the contact protective compound inside the nut loses its elasticity, characterised by frequent loosening.
- When the nut wear and tear reaches the value of $a = H/2$.

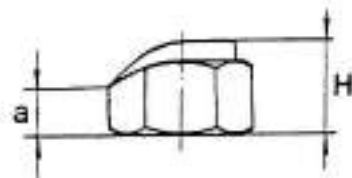

**ALWAYS USE ORIGINAL PARTS FROM FPM AGROMEHANIKA
BOLJEVAC TO ENSURE PROPER OPERATION OF YOUR MOWER.**

- If the mower is put out of operation for a longer period of time, remove all dirt and grass accumulated on the mower parts that come into contact with them. Pay particular attention to the inside of the protective canvas.
- Wash the machine thoroughly after cleaning.
- Discharge the oil from the step-up gear unit and cutting unit, and fill them with clean oil to the required level.
- Carefully remove excess oil with a cloth.
- Replace all damaged or broken cutters.
- Tighten all screws and nuts on the machine.
- Clean rusty spots and apply protective paint to all exposed surfaces.
- Store the cutting unit in the operating position.
- Remove the V-belts and keep them in a dry place.
- Raise the machine onto a wooden platform under a roof or in a separate room.



CAUTION:

1. **ALWAYS USE A CAB TRACTOR FOR DRIVER SAFETY.**
2. **NEVER WEAR CLOTHING THAT MAY GET CAUGHT IN THE PTO SHAFT OR OTHER ROTATING PARTS.**
3. **NEVER TRANSPORT OTHERS ON THE TRACTOR OR MOWER.**
4. **IT IS RECOMMENDED THAT A MECHANIC OF THE FPM AGROMEHANIKA DOO BOLJEVAC INSPECTS THE MOWER CONDITION, AND IN PARTICULAR THE CUTTERS AND OTHER PARTS.**
5. **ALWAYS FOLLOW THE INSTRUCTIONS GIVEN IN THIS MANUAL.**



ATTENTION: THIS SYMBOL IS USED IN THE MANUAL WHEN YOUR PERSONAL SAFETY IS CONCERNED. BE CAREFUL!



FPM AGROMEHANIKA DOO
Djordja Simeonovica 25
19370 Boljevac - Srbija

IZJAVA O USAGLAŠENOSTI 2006/42/EC

Mi,

FPM Agromehanika DOO,
Djordja Simeonovica 25, 19370, Boljevac, Srbija

ovim izjavljamo, kao proizvođači, u okviru naše odgovornosti, da je proizvod

Tip: Rotacione, diskaste kosačice
Model: FPM 627 726 - 4 diska
FPM 627 710 - 4 diska
FPM 627 678 - 4 diska
FPM 627 926 - 4 diska
FPM 627 927 - 5 diska
FPM 627 928 - 6 diska
FPM 604 183 - 3 diska
FPM 627 712 - 2 diska
FPM 627 715 - 7 diska
FPM 627 075 - 3 diska
FPM 627 713 - 5 diska
FPM 627 113 - 8 diska
FPM 627 134 - 4 diska
FPM 627 135 - 5 diska
FPM 627 136 - 7 diska

Godina proizvodnje: 2014

u saglasnosti sa zahtevima utvrdjenim po Evropskoj direktivi 2006/42/EC (za mašine).

Proizvod je usaglasen sa sledećim standardima:

- SRPS EN ISO 12100:2014
- SRPS EN ISO 13857:2010
- SRPS EN ISO 4354-1:2013
- SRPS EN ISO 4354-2:2013
- EN 1573:2009
- SRPS ISO 11684:1999
- SRPS EN ISO 11201:2014
- SRPS EN ISO 4413:2011

U Boljevacu,
24.12.2014.

Putem odgovorne osobe:
GENERALNI DIREKTOR
Borislav Rajić, m.s.s.ing

SPARE PARTS LIST

- Instructions for ordering spare parts -

- To order spare parts or components, please contact our spare parts sales department.
- Accessories and equipment whose ID number starts with 1, as well as the assembly and operation manual should be ordered from the machinery sales department.

The pictures below show numbered machine parts.

The captions specify: the number of the machine part, its ID number, quantity in the mower assembly, and, if necessary, size, the applicable standard and the required tightening torque. This spare parts list is prepared for two mower ranges. Make sure to order parts for the mower you own. Please also observe additional descriptions.

In order to avoid misunderstandings and wrong delivery, always specify the following information when ordering parts:

- machine name and number (series, №)
- name and number of the spare part (as per this list)
- quantity of the required spare parts
- desired delivery method (by mail, express post, etc.)
- customer's full address (including zip or postal code)



Imprinted on your machine's nameplate shown in this picture are series and factory number.

In order to resolve your warranty claim, we need the series and factory number information. Please enter these numbers immediately upon machine delivery in the original manual.



ABBREVIATED DESIGNATIONS

DNO	Additional non-essential equipment	Q	Number of items (quantity), if required
:	For	*	See note
< >	Except		Direction of movement
>	From to ...		Direction of rotation
Zam	Replaces		Parts and components package
\emptyset	Diameter	ZA	Replaceable with one or multiple parts
> <	Thickness	D.P	Washer thickness
T1N	For vineyard tractors	DPS	Washer thickness for reducing clearance.
T1	For tractors of category I		
T2	For tractors of category 2		
T3	For tractors of category 3		

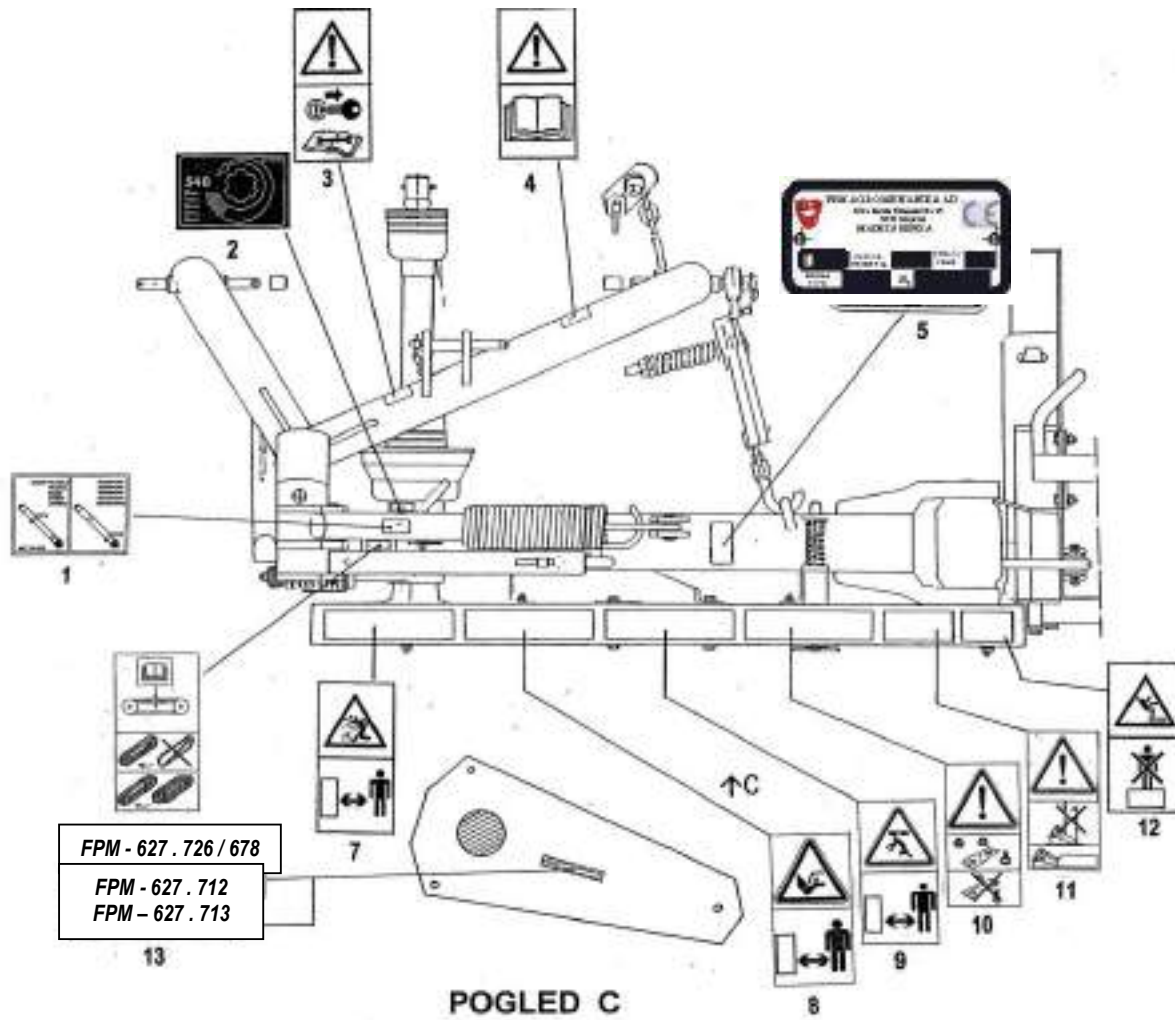

FPM - 627 . 726 / 678
FPM - 627 . 712
FPM - 627 . 713

- 1. 627 12 892
- 2. 627 10 762
- 3. 627 14 747
- 4. 627 14 746
- 5. 627 10 319
- 6. 627 14 754
- 7. 627 14 748
- 8. 627 14 749
- 9. 627 14 750
- 10. 627 14 752
- 11. 627 14 753
- 12. 619 81 164
- 13. 627 16 843-for FPM 627 726
- 13. 627 12 861-for FPM 627678
- 13. 627 14 086-for FPM 627 712
- 13. 627 15 687-for FPM 627 713

STEP-UP GEAR UNIT FOR FPM 627 712/726/678/713

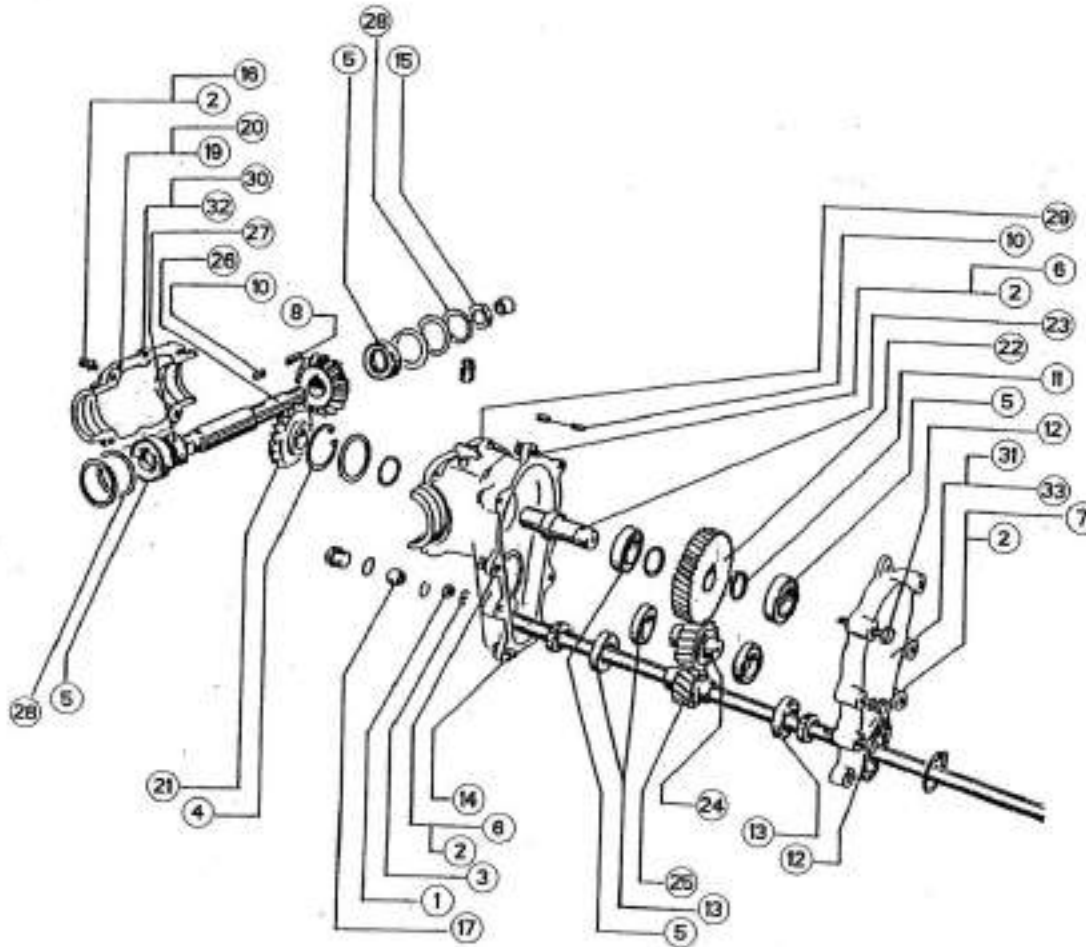

IDENTIFICATION NUMBER FOR ORDERING

1.	000 00 062	4	M12
2.	000 00 071	13	B10
3.	000 00 072	4	B12
4.	000 00 084	1	62
5.	000 02 016	4	6206
6.	000 02 191	3	M10x25
7.	000 10 078	2	M10x20
8.	000 05 334	1	A8x7x45
9.	000 05 336	1	30
10.	000 05 559	3	A8x7x25
11.	000 05 578	1	30
12.	000 06 509	4	M12x60
13.	000 07 412	4	6006
14.	000 08 087	2	M10x35
15.	000 08 100	1	62x40x7
16.	000 08 105	6	M10x25
17.	627 10 640	1	
18.	000 15 651	1	M30x1.5
19.	507 01 089	2	
20.	507 01 091	2	
21.	627 10 519	2	
22.	627 10 521	1	
23.	627 10 522	1	
24.	627 10 523	1	
25.	627 10 524	1	
26.	627 10 525	1	
27.	627 10 526	1	
28.	627 10 528	2	
29.	627 10 551	1	
30.	627 10 553	1	
31.	627 10 555	1	
32.	627 10 641	2	
33.	627 10 643	1	

STEP-UP GEAR UNIT FOR FPM 627 712/726/678/713

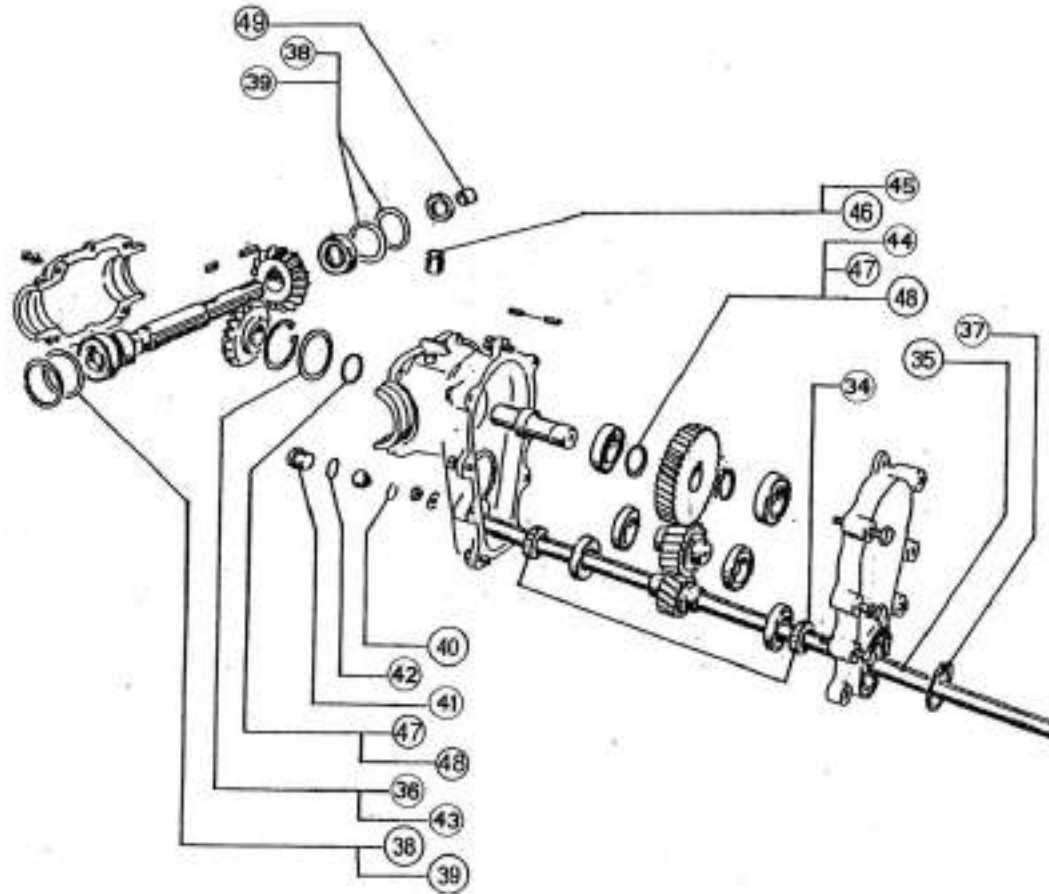

IDENTIFICATION NUMBER FOR ORDERING

34.	000 08 099	2	47x30x7
35.	627 14 084	1	3 discs
35.	627 10 516	1	4 discs
35.	627 15 699	1	5 discs
36.	627 10 529	pp	(1)
37.	627 10 644	1	
38.	627 10 645	pp	(2)
39.	627 10 646	pp	(2)
40.	627 10 647	1	
41.	627 10 648	1	
42.	627 10 649	1	
43.	627 10 686	pp	(1)
44.	627 12 152	pp	(1)
45.	627 15 140	1	
46.	627 15 183	1	
47.	810 01 524	pp	(2)
48.	810 01 525	pp	(2)
49.	810 01 528	1	

CUTTING UNIT FOR FPM 627 726/678;FPM 627 713

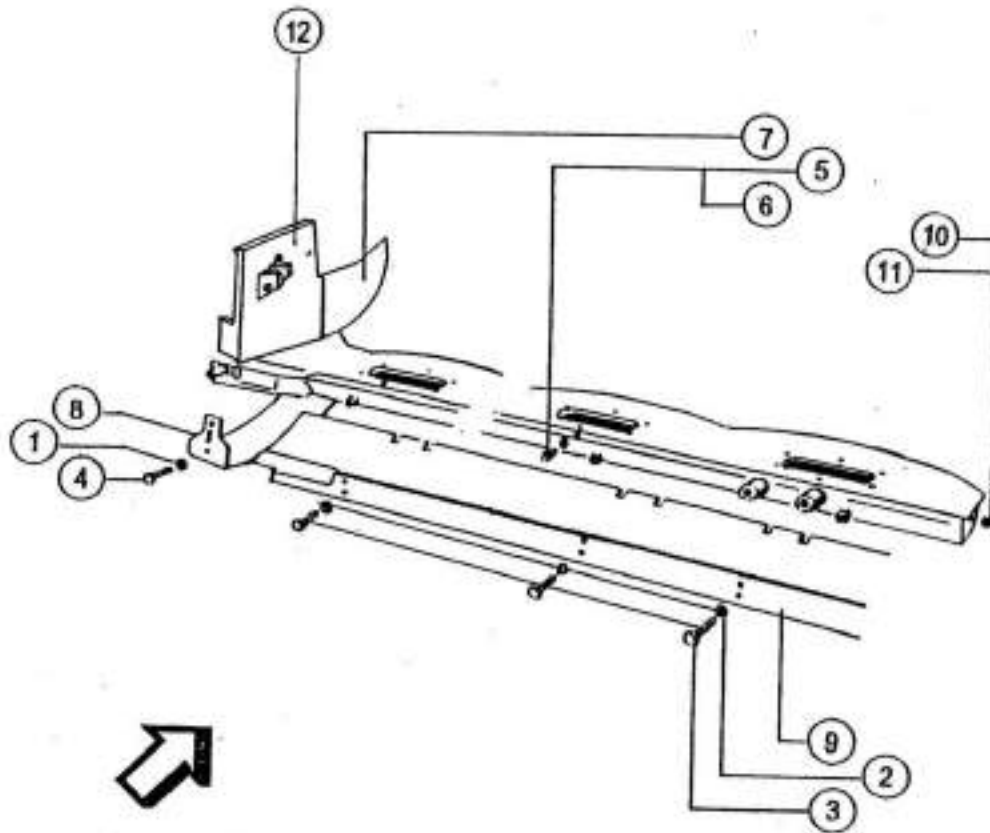

IDENTIFICATION NUMBER FOR ORDERING

1.	000 00 066	1	12
2.	000 02 493	4	10
3.	000 04 636	4	M10x20
4.	000 05 324	1	M12x25
5.	501 10 328	1	
6.	627 10 651	1	
7.	627 13 459	1	
8.	627 13 462	1	
9.	627 12 878	1	4diska
9.	627 15 671	1	5 discs
10.	627 15 140	1	
11.	627 15 183	1	
12.	627 15 771	1	4diska
12.	627 15 780	1	5 discs

CUTTING DISC TRANSMISSION

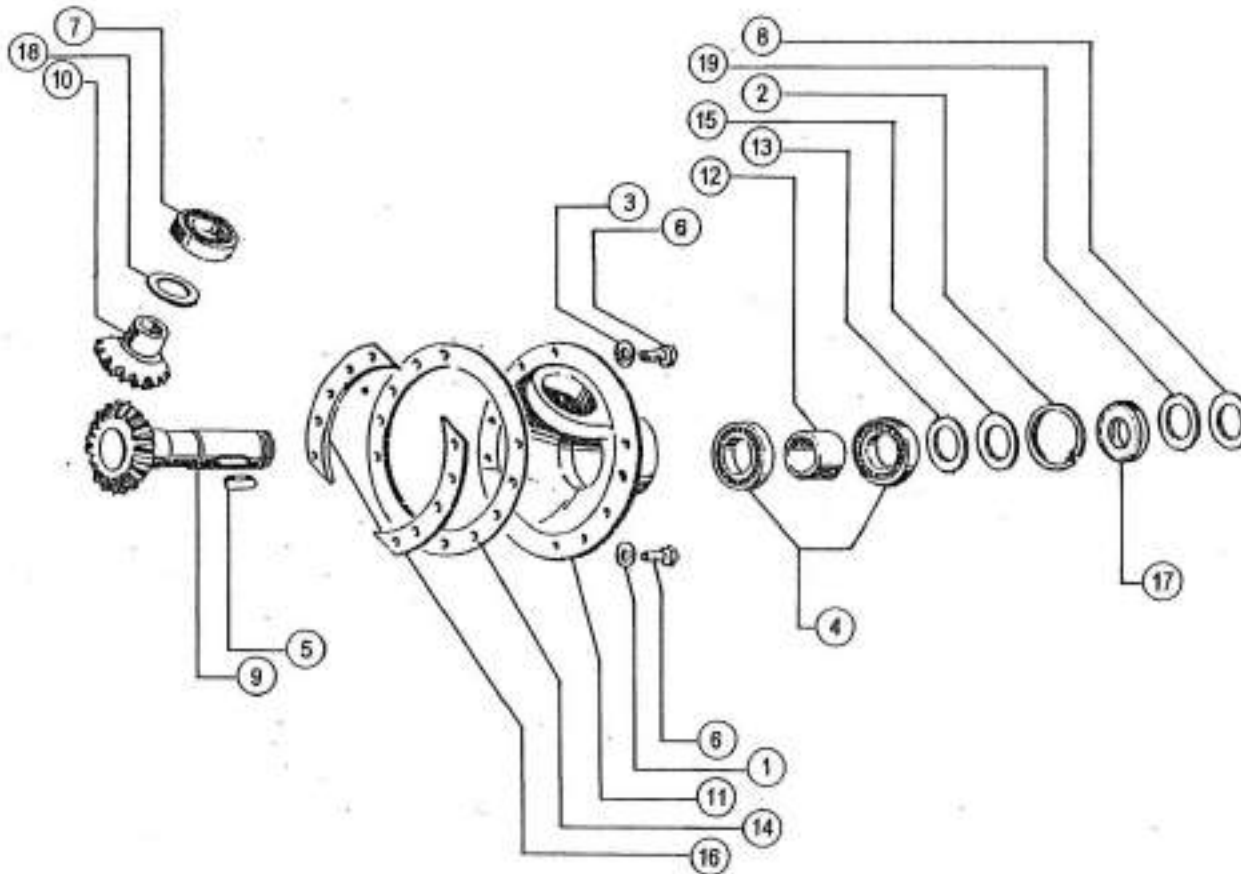

IDENTIFICATION NUMBER FOR ORDERING			
1.	000 00 070	7	B8
2.	000 00 084	1	62
3.	000 04 226	3	8
4.	000 04 227	2	6007
5.	000 05 325	1	a8x7x32
6.	000 05 333	10	M8x25
7.	000 07 412	1	6006
8.	627 10 177	PP	(2)
9.	627 10 511	1	
10.	627 10 512	1	
11.	627 10 514	1	
12.	627 10 515	1	
13.	627 10 529	PP	(1)
14.	627 10 629	1	
15.	627 10 686	PP	(1)
16.	627 12 679	2	
17.	627 15 191	1	35x62x7
18.	810 01 524	PP	(1)
19.	810 01 525	PP	(1)

CUTTING ELEMENTS BRACKETS FOR FPM 627 726/678

IDENTIFICATION NUMBER FOR ORDERING

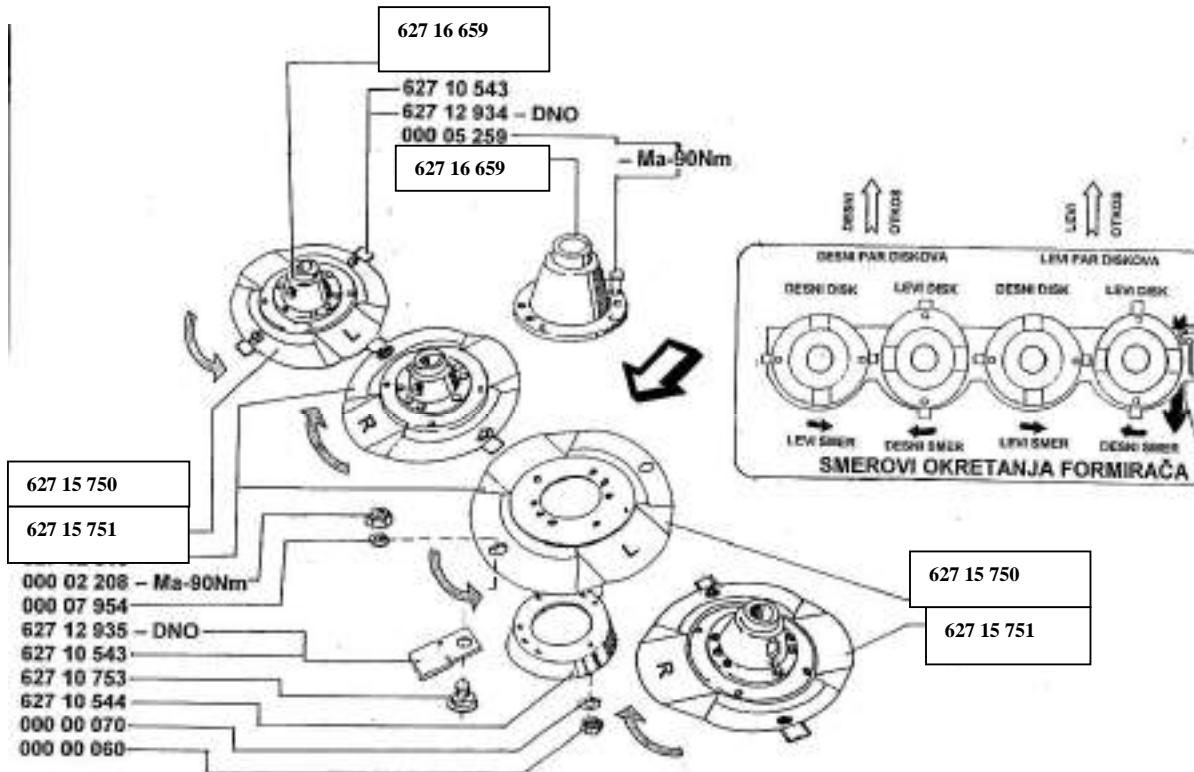

LEGEND
L - LEFT - LEFT ROTATION
R - RIGHT - RIGHT ROTATION

000 00 060	24	M8
000 00 070	24	B8
000 02 208	8	M10
000 05 259	24	M8x25
000 07 954	8	B10
627 16 659	4	
627 10 543	8	
627 10 544	4	
627 10 753	8	
627 15 750	2	
627 15 751	2	
627 12 934		DNO
627 12 935		DNO

CUTTING ELEMENTS BRACKETS FOR FPM 627 712

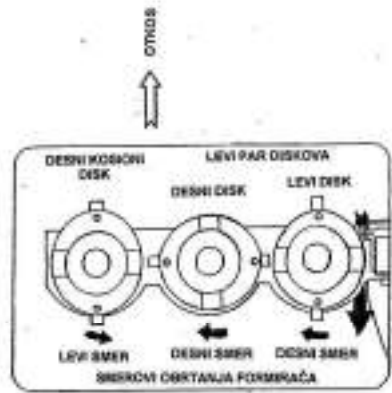
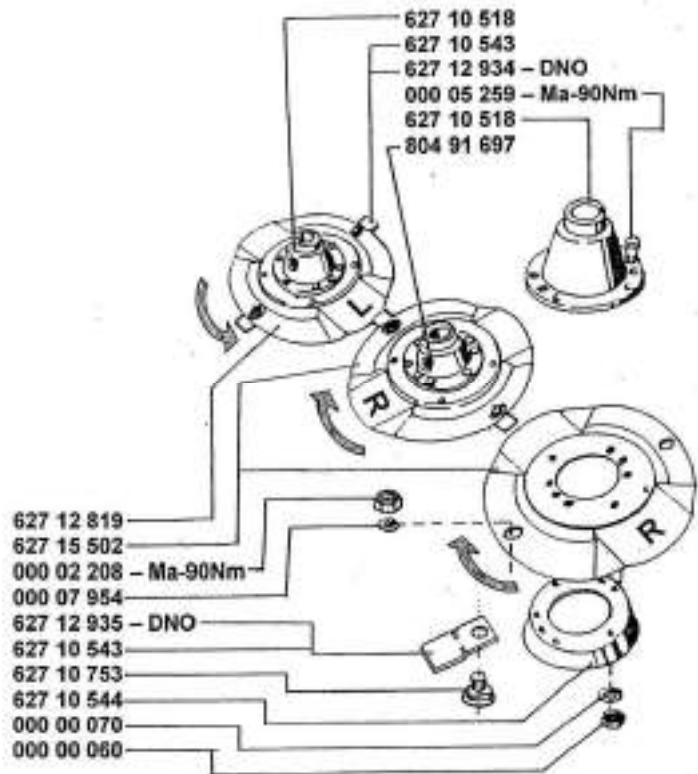

IDENTIFICATION NUMBER FOR ORDERING

000 00 060	18	M8
000 00 070	18	B8
000 02 208	6	M10
000 05 259	18	M8x25
000 07 954	6	B10
627 10 518	2	
627 10 543	6	
627 10 544	3	
627 10 753	6	
627 12 819	1	
627 12 934		DNO
627 12 935		DNO
627 15 502	2	
804 91 697	1	

LEGEND

L - LEFT - LEFT ROTATION
 R - RIGHT - RIGHT ROTATION

R

CUTTING ELEMENTS BRACKETS FOR FPM 627 713

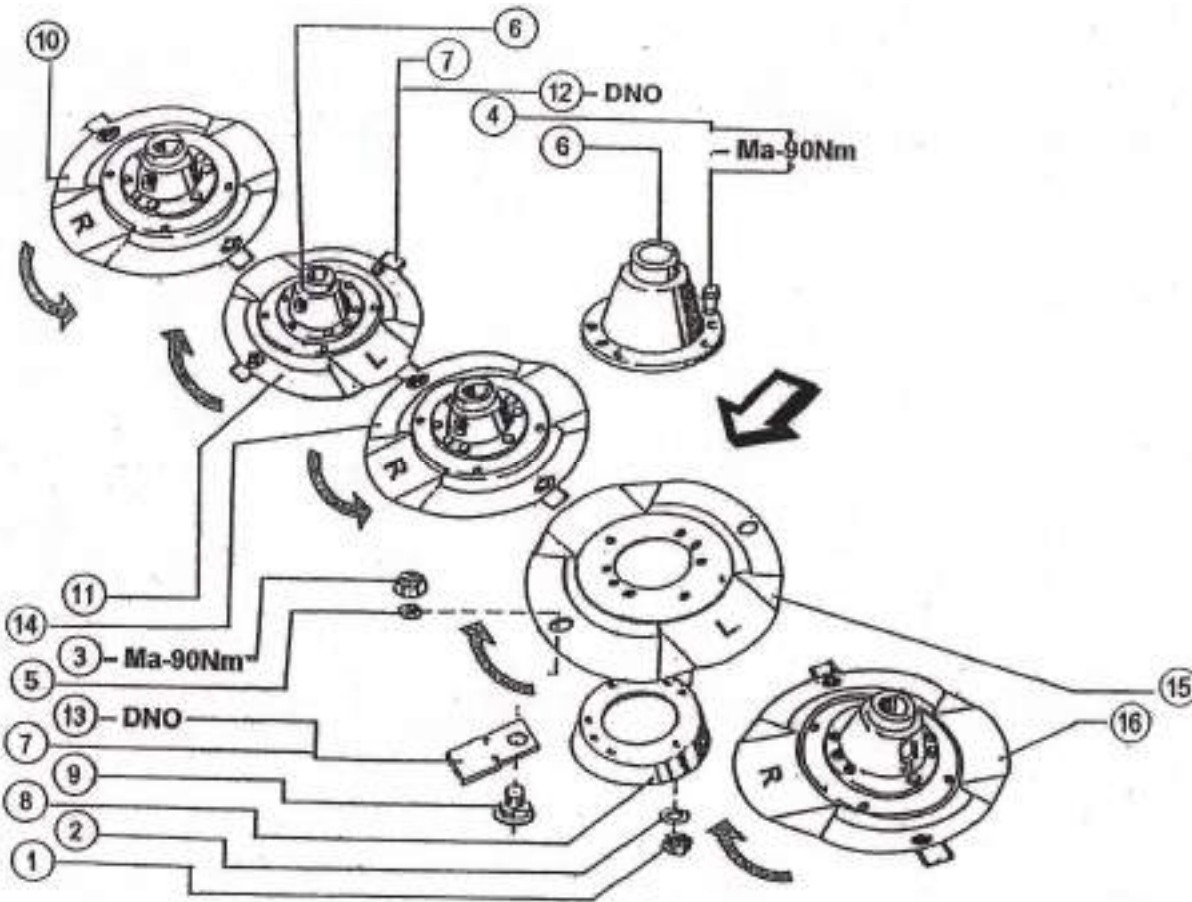

IDENTIFICATION NUMBER FOR ORDERING

1.	000 00 060	30	M8
2.	000 00 070	30	B8
3.	000 02 208	10	M10
4.	000 05 259	30	M8X25
5.	000 07 954	10	B10
6.	627 10 518	5	
7.	627 10 543	10	
8.	627 10 544	5	
9.	627 10 753	10	
10.	627 15 504	1	
11.	804 91 699	1	
12.	627 12 934		DNO
13.	627 12 935		DNO
14.	627 14 115	1	
15.	627 10 754	1	
16.	627 10 755	1	

GRUPA:PRIKLJUCNI I NOSECI RAM

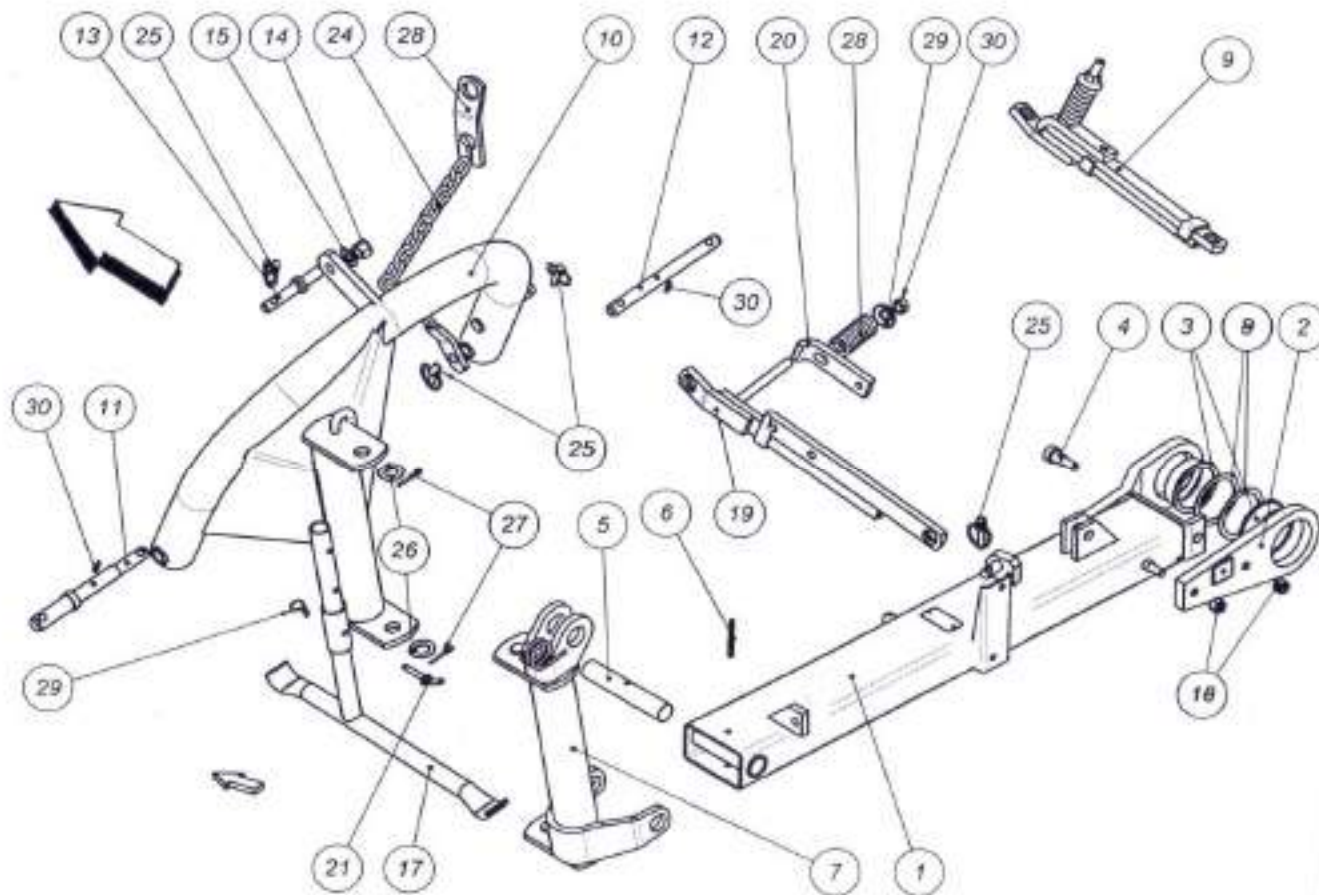

R.BROJ	IDENT. NUMERA	KOM
1	627 16 375	1
2	627 15 734	1
3	627 13 382	1
4	627 13 416-M14X1.5	1
5	627 16 376	1
6	8X80-JUS M.C2.230	1
7	627 16 372	1
8	627 16 612-84.5X105X2.0	2
9	627 16 165	1
10	627 16 380	1
11	627 16 401	1
12	627 13 022	1
13	627 16 404	1
14	M20X1.5-JUS M.B1.622	1
15	A20-JUS M.B12.011	1
16	M14X1.5-JUS M.B1.623	2
17	627 12 049	1
18	627 12 682	1
19	627 16 170	1
20	627 13 059	1
21	627 12 842	1
22	611 20 010	4
23	B 24-JUS M.B2.011	2
24	5X40-JUS M.C2.230	2
25	627 12 838	1
26	805 40 784	1
27	6X35-JUS M.C2.230	2
28	627 10 618	1
29	627 12 011	1
30	M16-JUS M.B1.601	1

CONNECTING AND SUPPORT FRAME FOR 627 713 – GMD 55 SELEKT

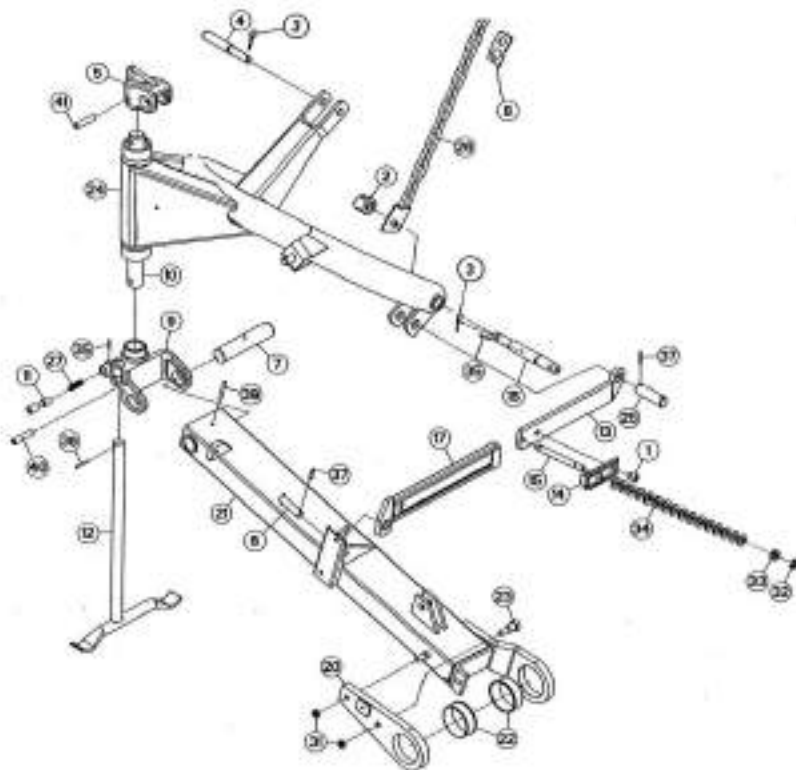

IDENTIFICATION NUMBER FOR ORDERING			
1.	627 13 346	1	
2.	627 13 434	1	
3.	611 20 010	2	
4.	627 10 683	1	
5.	627 13 419	1	
6.	000 07 948	1	
7.	627 13 429	1	
8.	627 12 838	1	
9.	627 13 420	1	
10.	627 13 428	1	
11.	627 13 267	1	
12.	627 13 365	1	
13.	627 13 340	1	
14.	627 13 344	1	
15.	627 13 347	1	
16.			
17.	627 13 335	1	
18.	627 15 300	2	
19.			
20.	627 15 734	1	
21.	627 15 716	1	
22.	627 13 382	2	
23.	627 13 416	1	
24.	627 15 100	1	
25.			
26.	627 13 430	1	
27.	505 05 201	1	
28.			
29.			
31.			
32.	000 05 329	2	14x1.5
33.	000 05 350	1	M16x1.5
34.	627 14 757	1	
35.	627 14 756	40	
36.	000 05 345	3	6x45
37.	000 05 341	1	4x40
38.	000 05 250	2	
39.	000 05 330	1	8x80
40.	000 05 331	2	16x65

MOWER SUPPORT FRAME FOR FPM 627 712

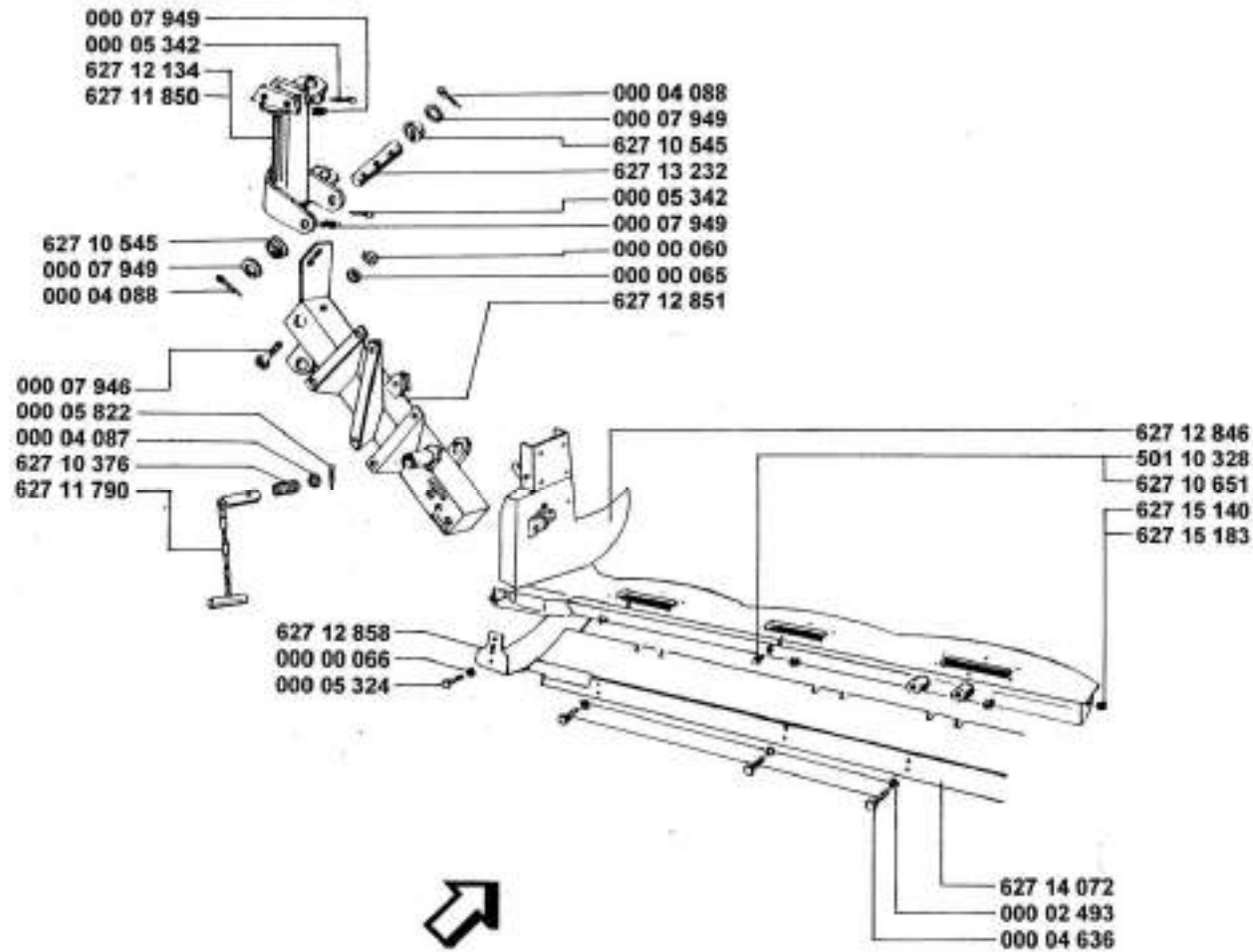

IDENTIFICATION NUMBER FOR ORDERING

000 00 060	1	M8
000 00 065	1	8
000 00 066	1	12
000 02 493	3	10
000 04 087	1	20
000 04 088	2	6,3x45
000 04 636	3	M10x20
000 05 324	1	M12x25
000 05 342	2	5x40
000 05 822	1	4x32
000 07 946	1	M8x90
000 07 949	4	27
501 10 328	1	
627 10 376	1	
627 10 545	2	
627 10 651	1	
627 10 790	1	
627 11 850	1	for MPS
627 12 134	1	for HPS
627 12 846	1	
627 12 851	1	
627 12 858	1	
627 13 232	1	
627 14 072	1	
627 15 140	1	
627 15 183	1	

HYDRAULIC LIFTING DEVICE FOR FPM 627 678

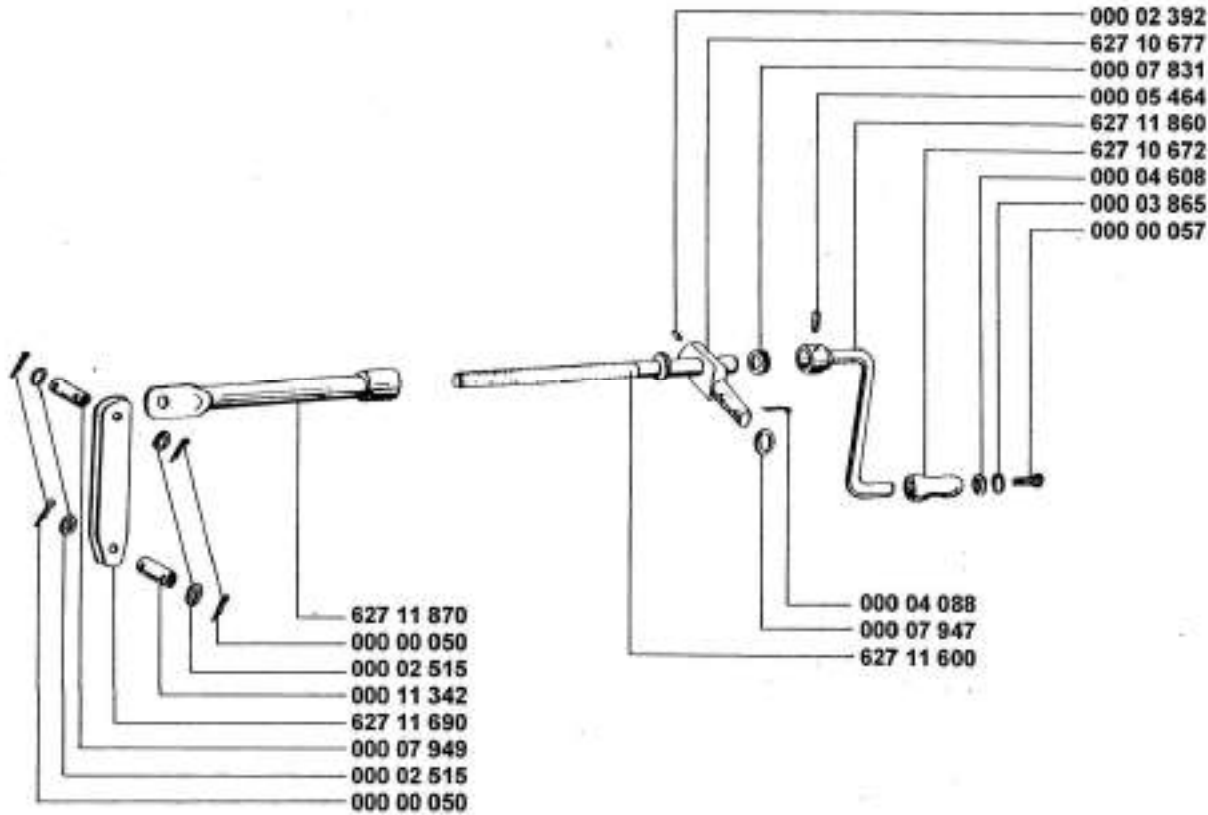

IDENTIFICATION NUMBER FOR ORDERING

000 00 050	4	5x36
000 00 057	1	M8x15
000 02 392	1	AM6
000 02 515	4	20
000 03 865	1	8
000 04 088	1	6,3x45
000 04 608	1	8
000 05 464	1	6x40
000 07 831	1	51108 IKL
000 07 947	1	27
000 07 949	1	20x65
000 11 342	1	20x80
627 10 672	1	
627 10 677	1	
627 11 600	1	
627 11 690	1	
627 11 860	1	
627 11 870	1	

HYDRAULIC LIFTING DEVICE FOR FPM 627 726/713

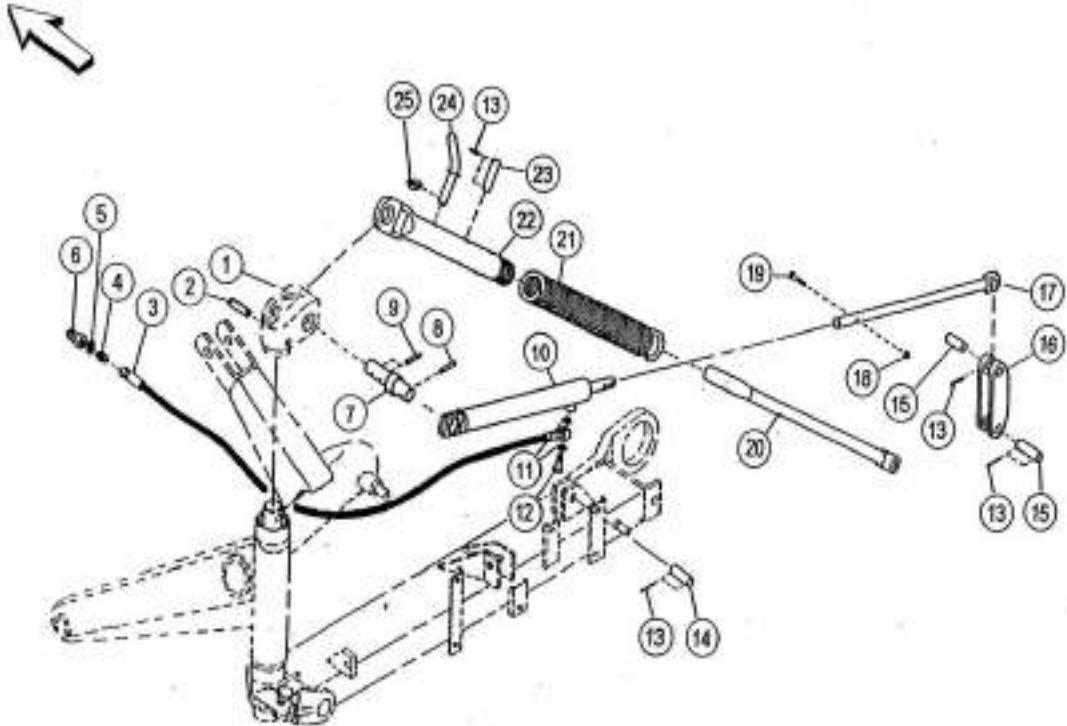

IDENTIFICATION NUMBER FOR ORDERING

1.			
2.			
3.	627 13 216	1	
4.	627 13 215	1	
5.	000 05 390	1	22x27
6.	627 13 217	1	
7.	627 16 382	1	
8.	000 05 464	2	6x40
9.	000 05 344	2	8x50
10.	627 16 384	1	
11.	000 05 389	2	A14x20
12.	627 13 214	1	
13.	000 05 250	8	5x30
14.			
15.	627 13 433	2	
16.	627 13 333	1	
17.	627 12 144	1	
18.	000 05 340	1	M14
19.	000 05 339	1	M14x50
20.	627 13 353	1	
21.	627 13 351	1	
22.	627 13 350	1	
23.	627 13 354	1	
24.	627 13 356	1	
25.	611 20 010	1	

HYDRAULIC LIFTING DEVICE FOR FPM 627 712

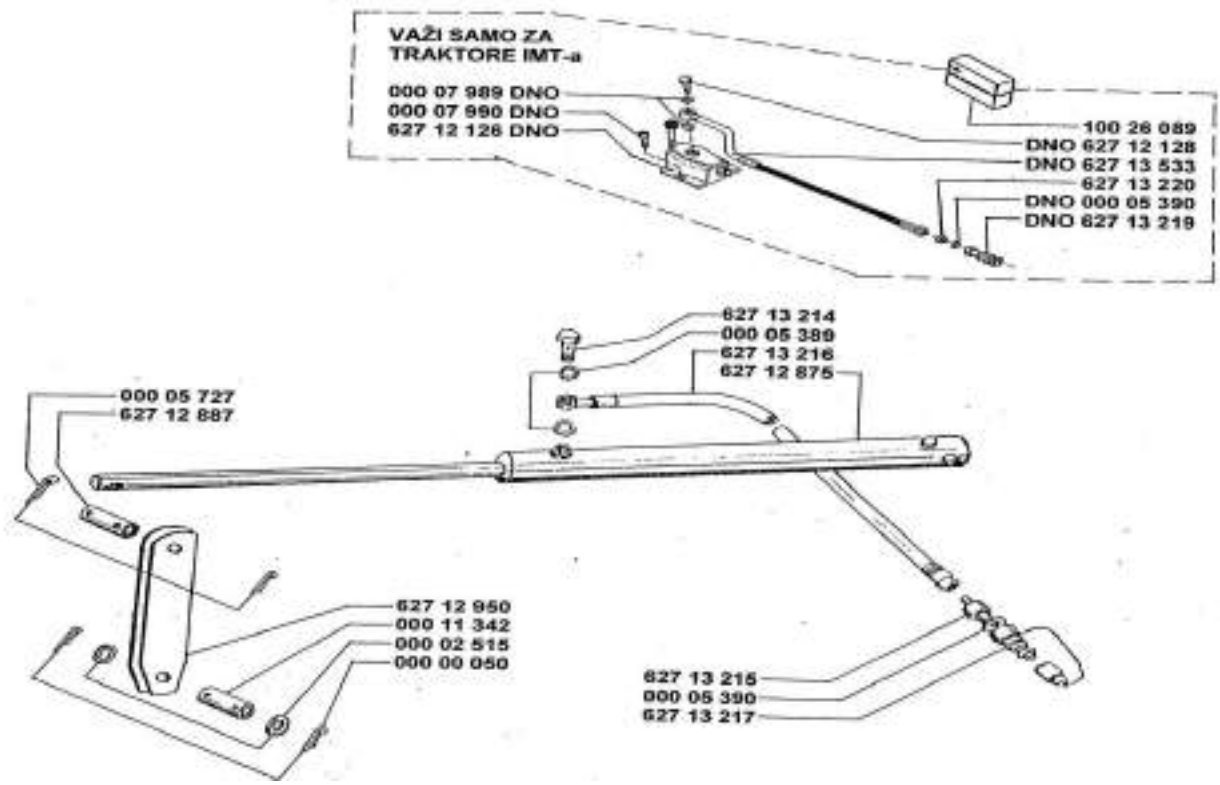

IDENTIFICATION NUMBER FOR ORDERING

000 00 050	2	5x36
000 02 515	2	20
000 05 389	2	14X20
000 05 390	1	22x27
000 05 727	2	4X25
000 11 342	1	20x80
627 12 875	1	
627 12 887	1	
627 12 950	1	
627 13 214	1	
627 13 215	1	
627 13 216	1	
627 13 217	7	

ONLY FOR IMT TRACTORS

000 05390	1	22x27DNO
000 07989	2	18x24DNO
000 07990	2	M12x35Zn DNO
627 12126	1	DNO
627 12128	1	DNO
627 13219	1	DNO
627 13220	1	DNO
627 13533	1	DNO
100 26089	1	

BALANCING ROD FOR FPM 627 712

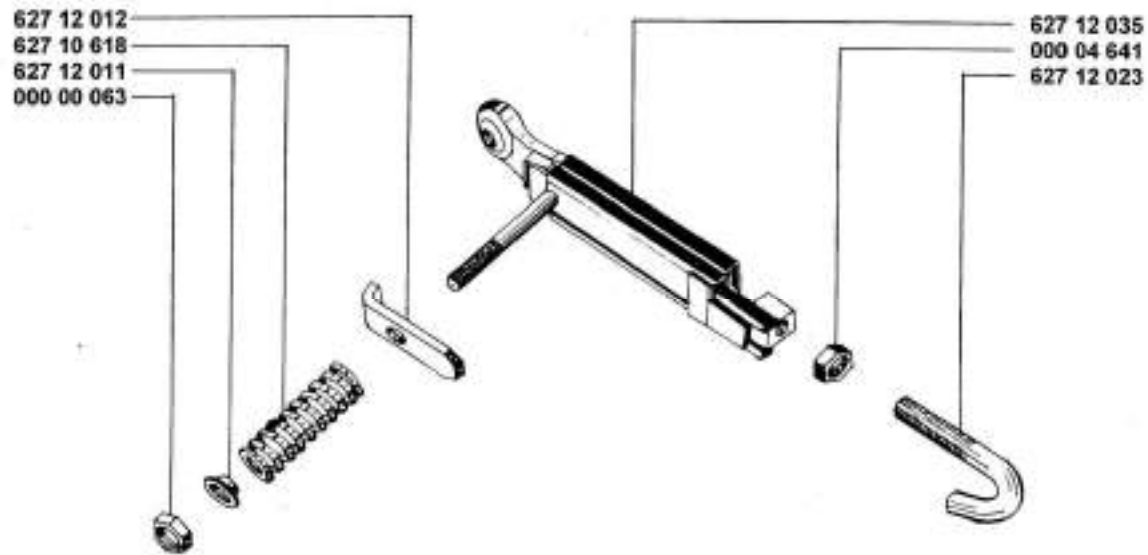

IDENTIFICATION NUMBER FOR ORDERING

000 00 063	1	M16
000 04 641	1	M20x1.5
627 10 618	1	
627 12 011	1	
627 12 012	1	
627 12 023	1	
627 12 035	1	

PROTECTIVE FRAME FOR MOWER FPM 627 712

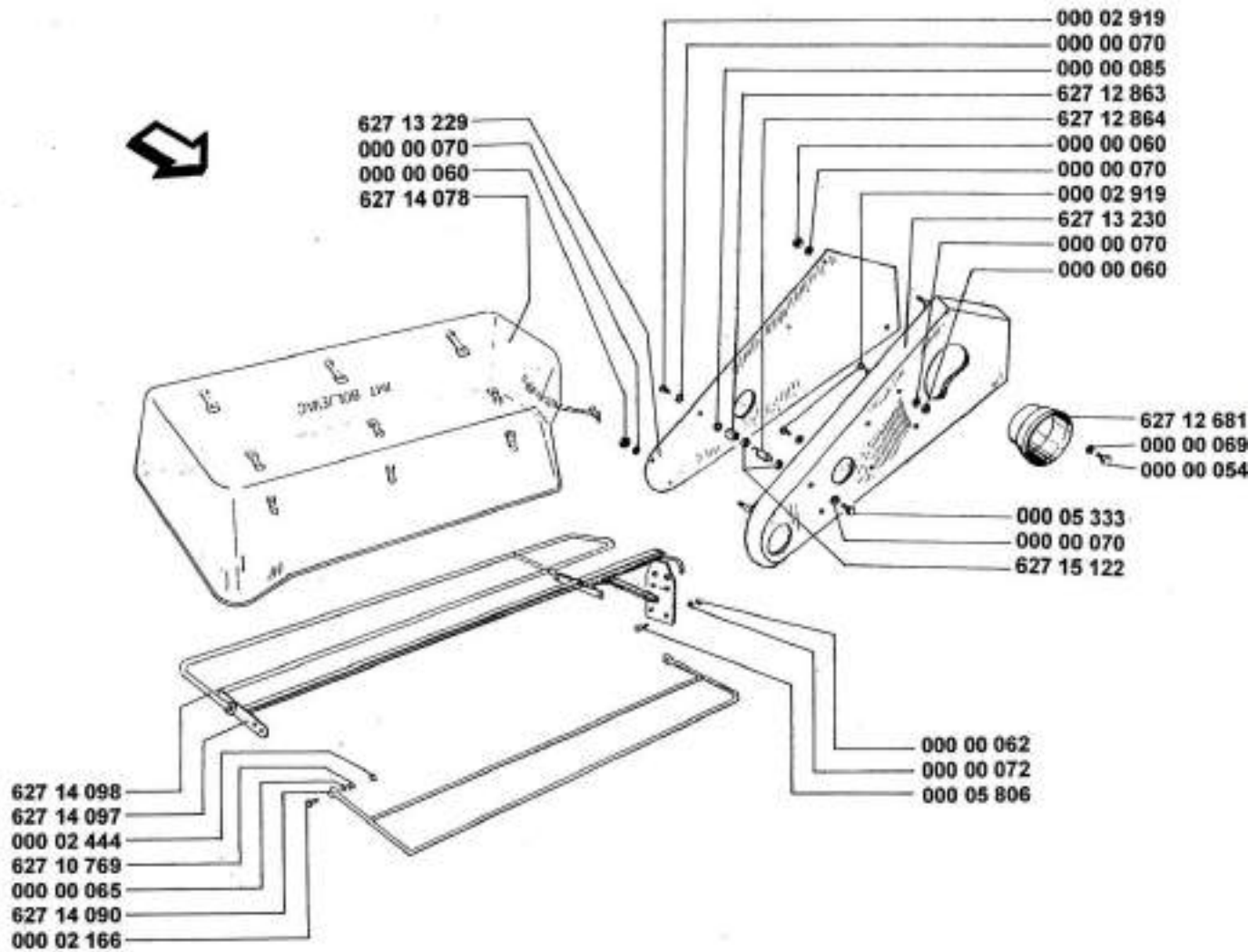

IDENTIFICATION NUMBER FOR ORDERING

000 00 054	4	M6x15
000 00 060	8	M8
000 00 062	6	M12
000 00 065	4	8
000 00 069	4	6
000 00 070	12	8
000 00 072	4	12
000 00 085	2	15
000 02 166	4	M8x30
000 02 444	4	M8
000 02 919	6	M8x20
000 05 333	2	M8x25
000 05 806	6	M12x30
627 10 769	4	
627 12 064	1	
627 12 130	1	
627 12 140	1	
627 12 681	1	
627 12 863	2	
627 12 864	2	
627 13 229	1	
627 13 230	1	
627 13 465	1	
627 15 122	4	6202-2Z

FLOATING ROD FOR FPM 627 712

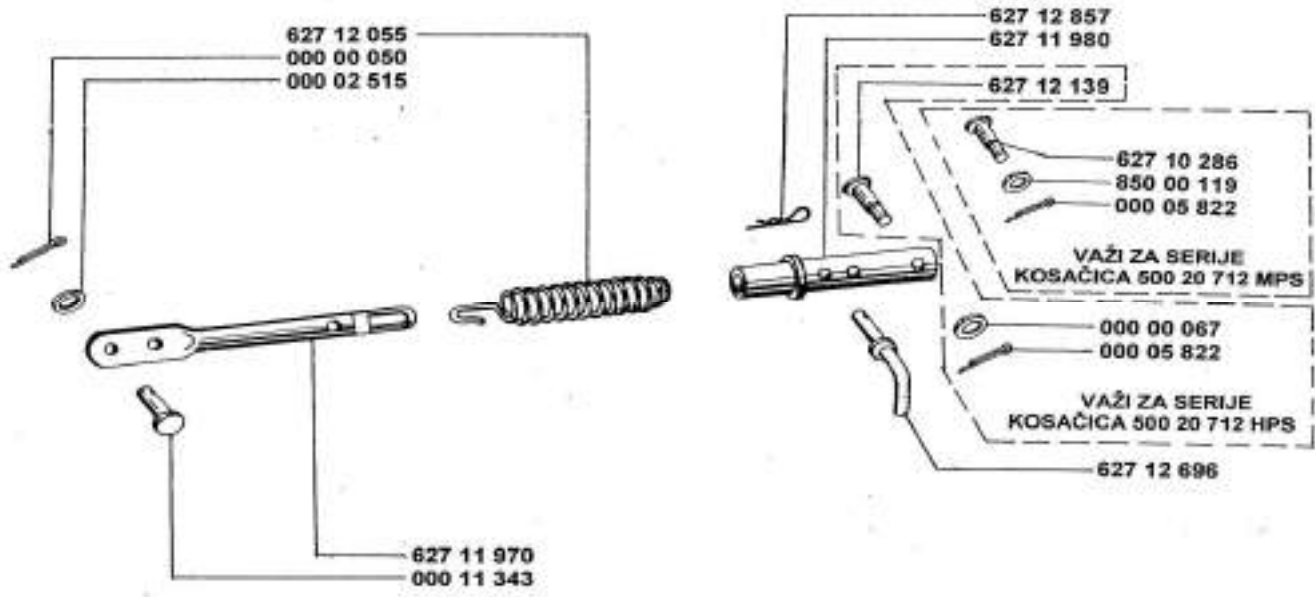

IDENTIFICATION

NUMBER FOR ORDERING

000 00 050	1	5x36
000 02 515	1	20
000 11 343		20x50
627 11 970	1	
627 11 980	1	
627 12 055	1	
627 12 696	1	
627 12 857	1	

FOR 500 20 712MPS MOWER RANGES

627 10 286	1	
850 00 119	1	
000 05 822	1	4X32

PROTECTION — MOULDBOARD FOR FPM 627 712

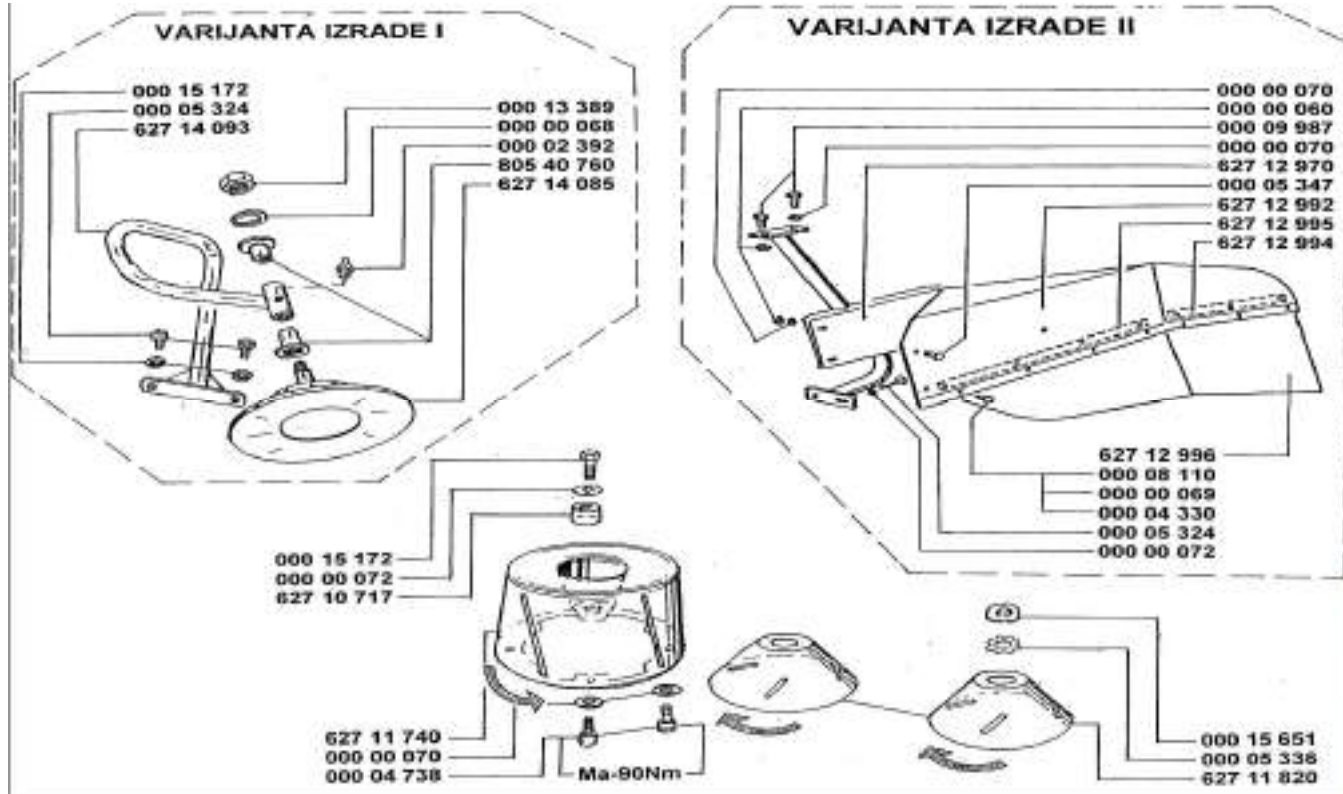

IDENTIFICATION NUMBER FOR ORDERING

VERSION I

000 00 068	1	16
000 00 070	4	B8
000 00 072	3	B12
000 02 392	1	AM6
000 04 738	4	A8x20
000 05 324	2	M12x25
000 05 336	2	30
000 13 389	1	M16x1.5
000 15 172	1	M12x1.5x25
000 15 651	2	M20x1.5
627 10 717	1	
627 11 740	1	
627 11 820	2	
627 14 085	1	
627 14 093	1	
805 40 760	1	

IDENTIFICATION NUMBER FOR ORDERING

VERSION II

000 00 060	4	M8
000 00 069	7	B6
000 00 070	8	B8
000 00 072	2	B12
000 04 330	7	M6
000 05 324	2	M12x25
000 05 347	3	M8x20
000 08 110	7	M6x20
000 09 987	2	M8x25
627 12 970	1	
627 12 992	1	
627 12 994	1	
627 12 995	1	
627 12 996	1	

MOULDBOARD AND SWATH BOARDS FOR FPM 627 726/678

IDENTIFICATION NUMBER FOR ORDERING

000 00 060	4	M8
000 00 065	3	A8
000 00 070	7	B8
000 00 072	3	B12
000 04 738	4	M8x20
000 05 324	2	M12x25
000 05 336	2	30
000 05 338	3	M8x18
000 09 987	2	M8x25
000 15 172	1	M12x1.5x25
000 15 651	3	M30x1.5
627 10 717	1	
627 11 740	1	
627 11 760	1	
627 11 820	2	
627 16 368	1	
627 16 378	1	

PROTECTION — MOULDBOARD FOR FPM 627 713

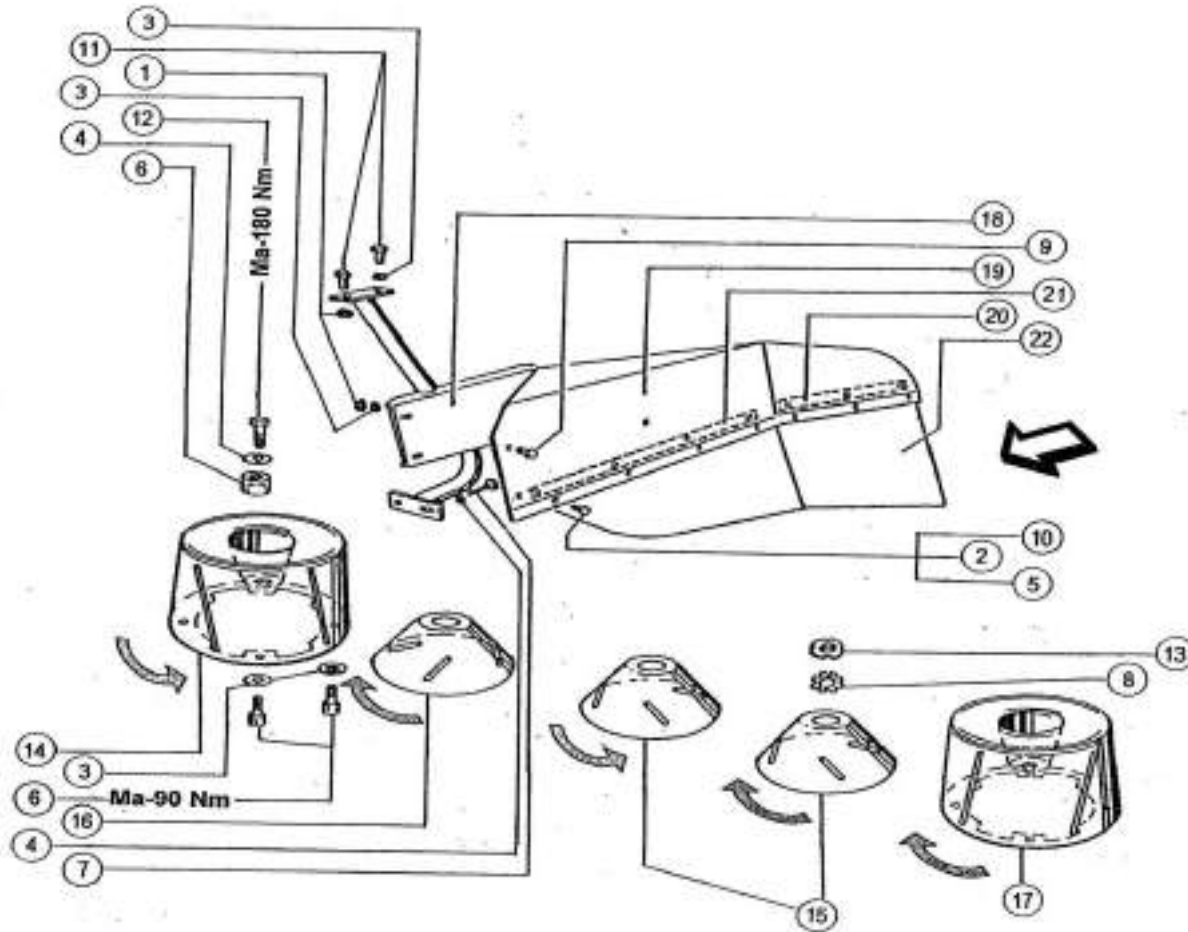

IDENTIFICATION NUMBER FOR ORDERING

1.	000 00 060	4	M8
2.	000 00 069	7	B6
3.	000 00 070	8	B8
4.	000 00 072	2	B12
5.	000 04 330	7	M6
6.	000 04 738	4	M8X20
7.	000 05 324	2	M12X25
8.	000 05 336	2	30
9.	000 95 347	3	M8X20
10.	000 08 110	7	M6X20
11.	000 09 987	2	M8X25
12.	000 15 172	1	M12X1.5X25
13.	000 15 651	2	M30X1.5
14.	627 11 740	1	
15.	627 11 760	1	
16.	627 11 820	2	
17.	627 12 853	1	
18.	627 15 761	1	
19.	627 12 992	1	
20.	627 12 994	1	
21.	627 12 995	1	
22.	627 12 996	1	

CONNECTING FRAME FOR MOWER FPM 627 712

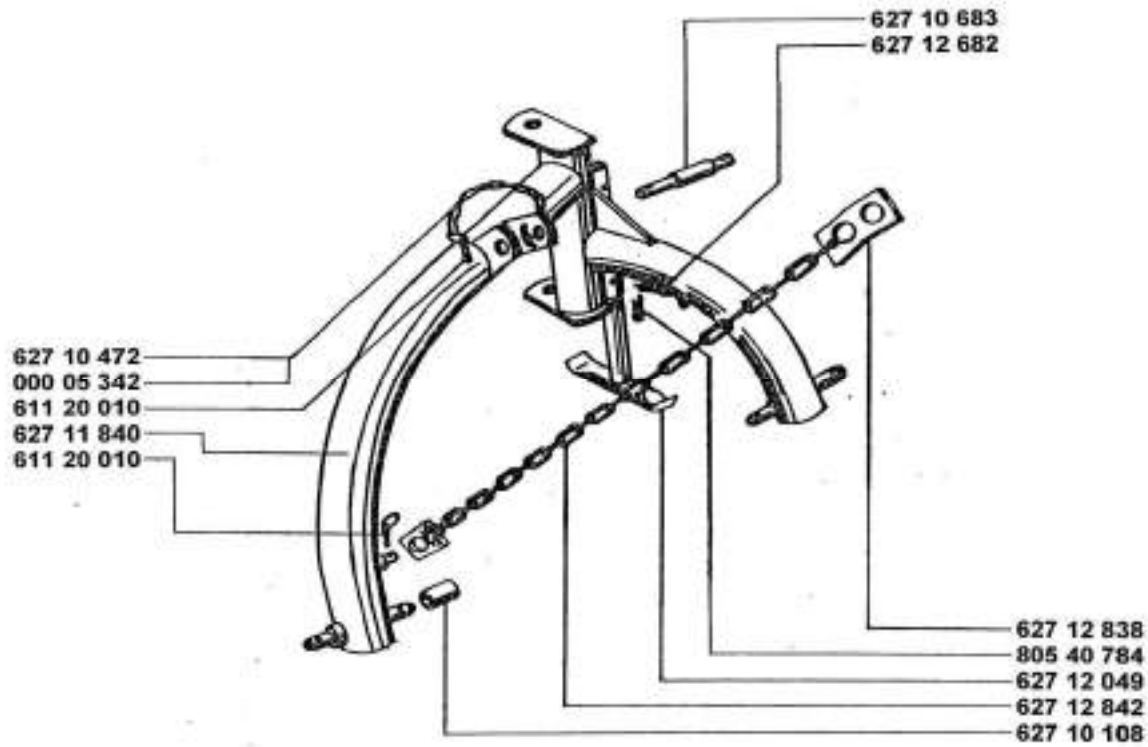

IDENTIFICATION NUMBER FOR ORDERING

000 05 342	1	5x40
611 20 010	2	
627 10 108	2	
627 10 472	1	
627 10 683	1	
627 11 840	1	
627 12 049	1	
627 12 682	1	
627 12 838	1	
627 12 842	1	
805 40 784	1	

DRIVE PULLEY FPM 627 712

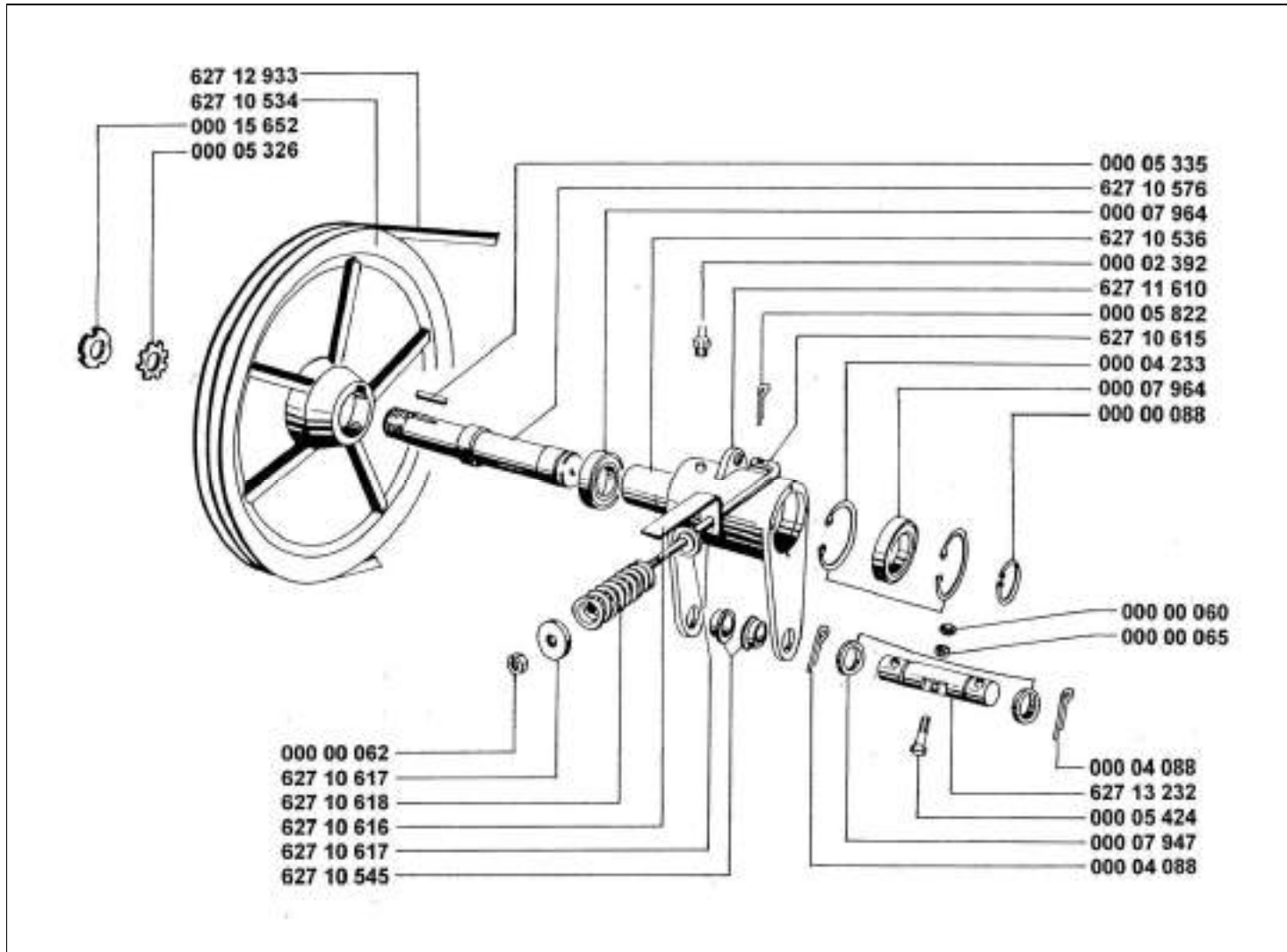

IDENTIFICATION NUMBER FOR ORDERING

000 00 060	1	M8
000 00 062	1	M12
000 00 065	1	8
000 00 088	1	35
000 02 392	1	AM6
000 04 088	2	6,3x45
000 04 233	2	72
000 05 326	1	40
000 05 335	1	A12x8x56
000 05 424	1	M8x50
000 05 822	1	4x32
000 07 947	3	27
000 07 964	2	6207 Z
000 15 652	1	M40x1.5
627 10 534	1	
627 10 536	1	
627 10 545	2	
627 10 576	1	
627 10 615	1	
627 10 616	1	
627 10 617	2	
627 10 618	1	
627 11 610	1	
627 12 933	3	
627 13 232	1	

GRUPA : ZAŠTITNA CIRADA

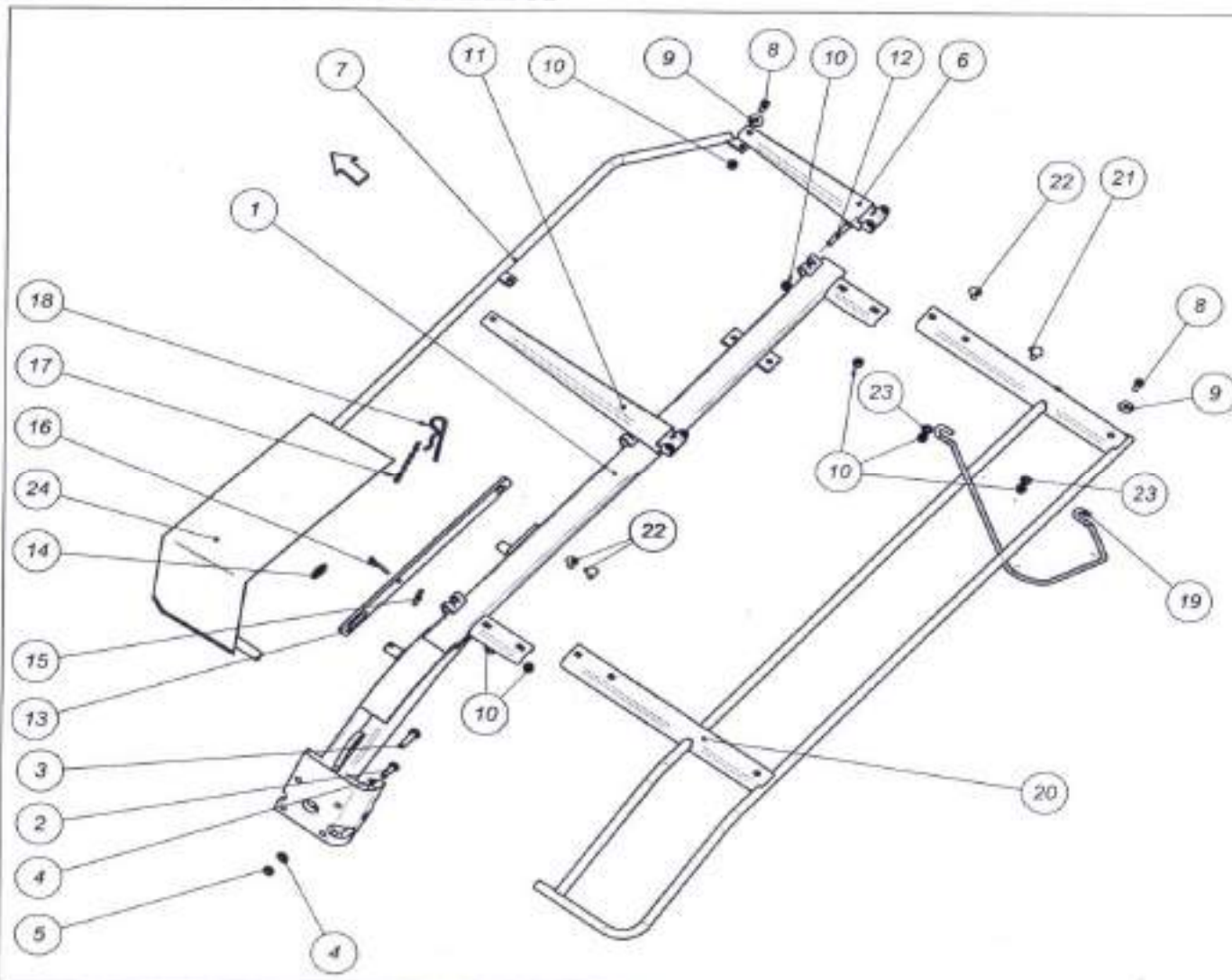

R.BROJ	IDENT.NUMERA	KC
1	627 16 420	1
2	M10X35 JUSM.B1.051	1
3	M12x45 JUS M.B1.053	1
4	A 12 JUSM.B2.011	2
5	M12-JUSM.B1.601	1
6	627 14 625	1
7	627 14 530	1
8	M10x25 - JUS M.B1.103	5
9	10-JU5M.B2.014	2
10	M10-JUSM.B1.622	11
11	627 14 630	2
12	M10X75 JUSM.B1.053	3
13	627 14 764	1
14	502 00 493	1
15	8X50-JUS M.C2.230	1
16	6X35-JUS M.C2.230	1
17	501 32 257	1
18	502 00 435	1
19	627 14 566	1
20	627 16 620	1
21	M10X30-JUS M.B1.171	1
22	M10X20-JUS M.B1.171	3
23	A 10 JUSM.B2.011	2
24	627 14 465	1

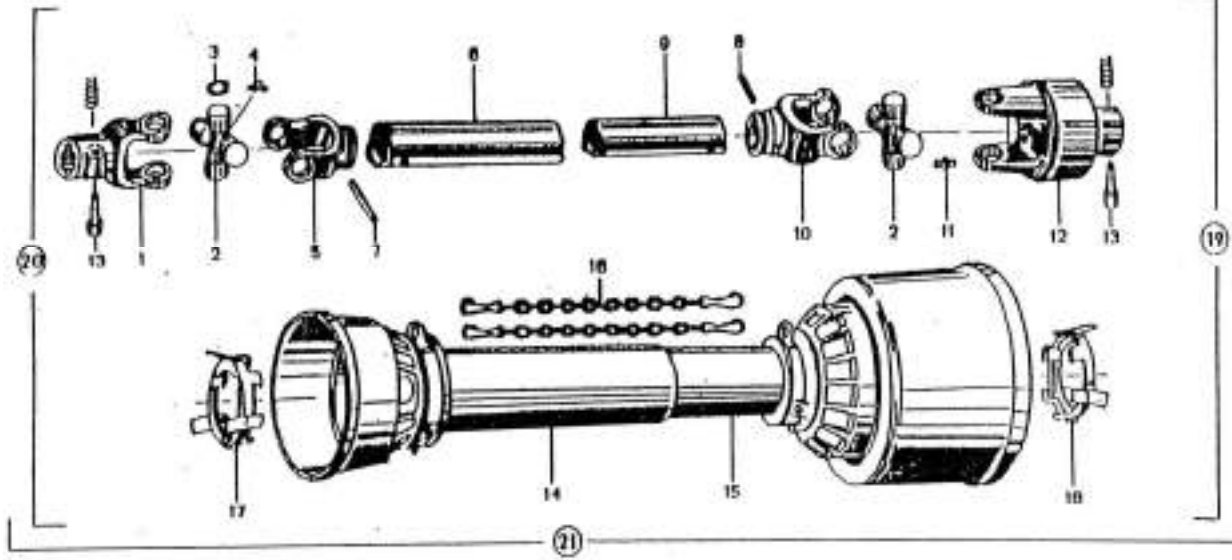

**IDENTIFICATION
NUMBER FOR ORDERING**

1			
2			
3			
4			
5			
6			
7			
8			
9			
10			
11			
12		1	51.12.00 (SJ-02)FKI Temerin
13			
14			
15			
16			<-> 660 mm
17			
18			
19			
20	627 11 810	1	<-> 990 mm
21			



This machinery meets the safety requirements of the European Machinery Directive.



**THE OPERATOR MUST OBSERVE ALL OCCUPATIONAL SAFETY AND HEALTH REGULATIONS; AS WELL AS ROAD SAFETY REGULATIONS. FOR YOUR PERSONAL SAFETY, USE ONLY ORIGINAL PARTS MANUFACTURED BY FPM AGROMEHANIKA DOO BOLJEVAC.
THE MANUFACTURER MAY NOT BE HELD LIABLE FOR THE CONSEQUENCES OF IMPROPER USE OR FAILURE TO COMPLY WITH THE RECOMMENDATIONS GIVEN IN THIS MANUAL**

